

# **Global Tender for**

**Power Cable Assemblies and Connectors for Thruster Controller Interface in MATSYA6000**



**NATIONAL INSTITUTE OF OCEAN TECHNOLOGY**  
VELACHERY – TAMBARAM MAIN ROAD, NARAYANAPURAM  
CHENNAI 600 100



NATIONAL INSTITUTE OF  
OCEAN  
TECHNOLOGY

**NOTICE INVITING TENDER (NIT)**



Form No.

NIOT/S&P/NIT

**e-Tender Schedule**

ननविदासख्या/ Tender No.	<b>NIOT/HVT/1317/2024-25</b>
कोजारी/ Tender Title	<b>Power Cable Assemblies and Connectors for Thruster Controller Interface in MATSYA6000</b>
ननविदाप्रणाली/Tender Mode	<b>CPP Portal (Open Tender- Dual Bid) -Global tender</b>
Tender Issue date/ निविदा जारी करने की तारीख	<b>08.06.2024</b>
Pre-Bid Meeting Date/ प्री-बिड मीटिंग की तारीख	<b>24.06.2024@15.00Hrs</b>
Tender Closing Date and Time/ निविदा बंद होने की तिथि और समय	<b>05.07.2024@11.00Hrs (IST)</b>
Tender Opening Date and Time/ निविदा खुलने की तिथि और समय	<b>05.07.2024@11.30Hrs (IST)</b>
Submission of EMD/ ईएमडिमाकरण	<b>INR 4,54,000/- or USD5450.52/-</b> a) Scanned copy of the EMD instrument to be uploaded in the CPP portal. <b>b) Original EMD should be submitted through courier/ speed post or in person dropped at the tender box before the closing date and time of the tender</b>
निविदाप्रलखउपलब्धास्थान/ Tender Documents available place	Tender documents can be freely downloaded from <a href="mailto:eprocare@nic.in">eprocare@nic.in</a> website <a href="http://www.niot.res.in">www.niot.res.in</a> till closing date and time of the Tender. The tender document fee is waived for downloading the Tender.
Bidding Type & Tender submission/ बोल्काप्रकार & ननविदाजमाकरणा	The tender is being Two Bid system, Techno- commercial Bid and BOQ (Price Bid) should be uploaded separately and electronically through CPP Portal <a href="http://www.eprocure.gov.in">www.eprocure.gov.in</a> /eprocare/app The price/cost should not be revealed along with the technical bid. In case, the price/cost is revealed the bid is considered as invalid and summarily rejected
ई-ननविदाक्ललयसहायिामनअल/ Help manual for e-tender	Bidders may download the help documents and Bidders manual kit from <a href="http://www.eprocure.gov.in">www.eprocure.gov.in</a> /eprocare/app For any technical queries related to operation of the Central Procurement Portal please mail to <a href="mailto:support-eproc@nic.in">support-eproc@nic.in</a> Helpdesk numbers are: Mobile Numbers- 91 8826246593 Tel: The 24 x 7 Help Desk Number 0120-4200462, 0120-4001002, 0120-4001005. For any issues / clarifications relating to the tender(s) published kindly contact the respective Tender Inviting Authority.
अपनप्रश्नईमलआईडपरभज/Send your queries to the email ID	<b><a href="mailto:hvt@niot.res.in">hvt@niot.res.in</a></b>

राष्ट्रीयसमद्रप्रौद्योगिकीसंस्थान NATIONAL INSTITUTE OF OCEAN TECHNOLOGY

वेलचरीताम्बरममेनरड VELACHERY TAMBARAM MAIN ROAD

नोरायणपुरम, चेन्नई 600 100 NARAYANPURAM, CHENNAI 600 100

रा.स.प्रौ.स. वेबसाइट/NIOT Website <http://www.niot.res.in/tenders>

## **GENERAL CONDITIONS OF CONTRACT (GCC)**

National institute of Ocean Technology, Chennai invites E-bids for **Power Cable Assemblies and Connectors for Thruster Controller Interface in MATSYA6000** at NIOT Chennai as per details given below.

**1.Submission of bids:** Bidders are requested to submit their Bid/quotation in two parts containing Technical proposal and price bid (BOQ) as Part-2 should be submitted electronically through CPP portal. The responsibility to ensure timely submission of bid lies with the bidder. Bids submitted through FAX or e-mail will not be considered. Bidders shall also attach scanned copies of all the requisite documents i.e. other certificates/documents specified in the NIT documents. The bids are to be submitted (electronically) as per the bidding type indicated in the front page of the NIT. Bidders are advised to submit their quotation in two Parts. **No manual tender is acceptable.**

**Part-1 should contain Techno-Commercial Bid** and duly signed blank price bid (without indicating the cost). All documents to be uploaded in the CPP portal only. **The price/cost should not be revealed in the technical bid, if the price/ cost is revealed, anywhere in the tender will be treated as invalid tender.**

**Part-2** should contain only the price bid (BOQ) indicating the cost  
The Part-1(Technical bid) and Part-2 (Price bid- BOQ) should be uploaded separately, indicating the Tender No, Tender date, Tender due date and time. Please note that to participate in the tender, Digital Signature (DSC) has to be obtained. If you are a regular supplier of NIOT it is requested to register your company with portal and to procure if not owned already.  
This NIT/ all corrigendum shall form part of the LOI / Contract.

2.Terms and conditions indicated in the NIT shall be superseded by the terms and conditions mentioned in the Special conditions of contract (SCC) as at Annexure wherever applicable.

### **3.Pre-qualification criteria for bidders**

#### **3(I). Technical**

(a) The Bidder or the corresponding OEM (in case the bidder is not the OEM for the Cable assemblies and Connectors) shall have manufactured/ supplied Underwater Cable assemblies/ Connectors rated for greater than or equal to 6000 m water depth at least once during the last 10 years, year ending 31.03.2024.

(b) Proof of execution/ supply such as copies of delivery acceptance/ copy of purchase order completion certificate/ Third party inspection report for past shipments by authorized certifying agency/ testimonials from past clients etc. to be submitted. Absence/ non-submission of documentary evidence as any of the above may lead to tender being non-responsive/ invalid.

#### **Note:**

"Bidder" including the term "tenderer", "consultant" or "service provider" in certain contexts means any eligible person or firm or company, including a consortium (that is an association of several persons, firms or companies), Authorized distributors, Agents etc. through a valid Original Equipment Manufacturers (OEM) authorization certificate for the purpose of this tender (Model format available in NIOT website) and pre-existing valid agreement participating in this tender process.

#### **3(II). Financial:**

(a) The average annual financial turnover of 'The bidder' during the last three years, ending on 31.03.2023 shall be at least **INR 6.8 Million or 68 lakhs** or equivalent in foreign currency at exchange rate prevalent on 'The Relevant Date') as per the annual report (audited balance sheet and profit & loss account) of the relevant period, duly authenticated by a Chartered Accountant/ Cost Accountant in India or equivalent in relevant countries shall be submitted.

(b) The net worth of the Bidder firm shall not be negative on 31.03.2023 'The Relevant Date' and also shall have not eroded by more than **30%** (thirty percent) in the last three years, ending on 'The Relevant Date' (i.e.) 31.03.2023.

**Note:**

**'Doctrine of Substantial Compliance'**: The Pre-Qualification Bidding (PQB) and Prequalification Criteria (PQC) are for short listing of sources who are competent to perform this contract to ensure best value for money from expenditure of Public Money. This process is neither intended to bestow any entitlement upon nor to create any rights or privileges for the Bidders, by way of overly hair-splitting or viciously legalistic interpretations of these criteria, disregarding the very rationale of the PQB and PQC. Keeping this caveat in view, interpretation by Procuring Entity would be based on common usage of terminologies and phrases in public procurement in accordance with the 'Doctrine of Substantial Compliance' and would be final.

**3.(III) Pre-Bid meeting:** Pre-bid meeting shall be held **on 24.06.2024 at 15.00 Hrs** through video conference to clarify queries from all potential bidders. Potential bidders are advised to send their queries sufficiently in advance by email to [hvt@niot.res.in](mailto:hvt@niot.res.in). The meeting link will be uploaded as a corrigendum. A Corrigendum will be issued based on pre-bid meeting clarifications and shall form part of the NIT

### **INSTRUCTION TO BIDDERS**

4.I Either the Indian Agent on behalf of the Principal/OEM or Principal/OEM itself can bid but both cannot bid simultaneously for the same item/product in the same tender.

4.II Quotation/ Offer/ Bid should preferably be made directly from the manufacturers. Either the agent on behalf of the foreign principle or the foreign principal directly could bid in a tender, but not both. Further, in cases where agents participate in a tender on behalf of one manufacturer, they should not be allowed to quote on behalf of another manufacturer along with the first manufacturer. Commissions and scope of services to/by the agents should be explicit and transparent in the bids/contracts.

**5.1 Security:** Any information / material / document supplied along with this tender or after placement LOI should not be disclosed or copied without written permission from NIOT.

**5.2 Contacting NIOT:** No correspondence / discussion / visits whatsoever will not be entertained on the subject unless specifically called by this office after opening the tender or clarifications in writing. Any violation of this will render the quotation invalid and the firm is liable to be removed from our approved vendor list. However, if vendor requires any clarification on the bid, the query may be mailed to [hvt@niot.res.in](mailto:hvt@niot.res.in)

**5.3 Tender opening:** All the tenderers can participate in the e-tender opening with proper authorization letter from the respective Company.

**5.4 Default in Performance:** If any Vendor is not successfully discharging their contractual obligations against the LOI /contract placed by NIOT within the agreed time limit, (OR) if there is any deficiency in performing such obligations, NIOT reserves the right to suspend such Vendor from their participation in future tenders of NIOT for a minimum period of one year. Even after revoking the suspension period the Vendor's performances till continues to be the same without any improvement, NIOT reserves right to BAN such Vendor permanently from participation in all the tenders of NIOT and organizations of MOES.

**6. Goods:** Goods should be supplied only on receipt of the LOI / signed contract from NIOT

**7. LOI Acceptance:** The successful bidder should submit LOI acceptance within 15 days from the date of LOI, along with the copy of the performance security instrument failing which it shall be presumed that the successful bidder is not interested and his bid security /EMD shall be forfeited.

**8. Signing of Contract:** On successful evaluation and declaration of the Successful bidder, initially a Letter of Intent will be issued by NIOT. The successful bidder should submit his acceptance of LOI within 15 days along with the deliverables as sought in the LOI and copy of power of attorney along with the Board resolution copy authorizing to sign the contract with NIOT. If the Director of the company is signing the contract the copy of the MOA to be submitted, upon receipt of acceptance of LOI and other relevant documents mentioned, the contract will be signed by NIOT.

**9. Change of Name after award:** Request / intimations with regard to change of name of the Contracting company or constitution of the contracting company after the tender opening or award of contract shall not be allowed as a matter of right. The bidders/ contractors are required to submit all relevant documents with regard to change of name or/and change of constitution and the circumstances leading to such change beforehand. It shall be the discretion of NIOT to proceed with the contract after such changes and in case, NIOT decides to proceed with the contract, it may require the bidder/contractor to execute further agreements with regard to execution/ implementation of the contract.

**10. One Bid per Bidder:** (i)A firm shall submit only one bid either individually or as a consortium / joint venture. A firm that submits either individually or, as a member of a consortium/joint venture, more than one bid will result in rejection of all the bids.

(ii)The OEM can authorize their agent to submit the bid on their behalf. But both the OEM & their agent cannot bid for the tender.

### **BIDDING CONDITION**

**11. Deadline for Submission of Bids:** e-Bids must be submitted only at the CPP portal specified in the Invitation for Bids cover page on or before the due date/extended due date thereof. All bidders are advised to take adequate care to plan for bid submission in CPP Portal well ahead of closing date and time and avoid any last-minute submission.

**12. Due date Extension, Corrigendum to NIT:** Any corrigendum including due date extension for NIT, Pre-bid minutes of meeting will be notified in CPP portal and NIOT website. Hence bidders are requested to watch the website for such due date extension and corrigendum if any.

**13. In case of the unscheduled holiday** in Chennai being declared on the scheduled closing / opening day of the tender, the next working day will be treated as the scheduled day of closing/opening of the tender.

**14. Unsolicited correspondences:** NIOT will not entertain any unsolicited correspondence or queries on the status of offer against this tender.

**15. Non-Receipt of tender:** NIOT will not be responsible for the non-submission/receipt of the tender due to any network problem or technical issues with bidder.

**16. Submission of tender by a tenderer** implies that he has read the Notice Inviting Tender and has made himself aware of the scope and specifications of the supply of the item.

**17. Bid Validity:** Bids shall valid and open for acceptance for a minimum of 120 days from the date of opening of Un-priced Techno-commercial Bids when fully compliant tender is submitted by the bidder without any requirement for NIOT to seek additional documents towards evaluation of pre-qualification and/or in ensuring conformance to the specification/requirements of the tender. In the event of any delay in evaluation attributable to the vendor, vendor shall agree to extend the bid validity by such a time taken by them in addition to above minimum bid validity. A Bid valid for shorter validity will be considered as a conditional bid and treated as invalid tender.

**18. Bid validity extension:** While NIOT will finalize the tender within the bid validity sought as per this NIT, due to circumstances beyond the control of NIOT, prior to expiry of the original Bid validity period; NIOT may request the Bidder for a specified extension of the bid validity without modifying RFP or Price. The request and the responses thereto shall be made in writing. A Bidder agreeing to the request will extend the validity of his Bid and Bid Security (EMD) correspondingly. When bid validity is extended EMD BG also deemed to have been extended automatically for which necessary action would be taken by the bidder to submit the extended BG well before the expiry of the current EMD BG validity.

**19. EMD / Bid security:** The bidder should upload the copy of the instrument of EMD /Bid security of **INR 4,54,000/- or USD5450.52/-** in form of Account Payee Demand Draft, Fixed Deposit Receipt, Banker's Cheque, Bank Guarantee, Insurance surety bond from any of the Commercial Banks drawn in favor of the Director NIOT.

The tenders without EMD shall be summarily rejected. No exemption for EMD will be entertained. After identifying the successful bidders, the EMD of the unsuccessful bidders shall be returned without interest after other than the MSME registered vendors. The EMD / Bid Security of the successful bidder will be returned after receipt of the performance security. The EMD stands forfeited in case the bidder withdraws or amends his bid after submission of tender document and tender closing date/time. (CPP portal permits all the bidder to modify/withdraw their bid before bid closing date/time).

**MSME:** "Micro and Small Enterprises (MSEs) as defined in MSE Procurement Policy issued by Department of Micro, Small and Medium Enterprises (MSME)" are exempt from submission of EMD (Bid security). Bidders claiming exemption of EMD under this rule (170 of GFR are however required to submit a signed Bid securing declaration (format to be enclosed) along with the relevant and valid exemption certificate issue by the appropriate authorities. Accepting that if they withdraw or modify their Bids during the period of validity, or if they are

awarded the contract and they fail to sign the contract, or to submit a performance security before the deadline defined in the request for bids document, they will be suspended for the period of one year from being eligible to submit Bids for tenders with NIOT and all the departments under MoES. Bid declaration format to be attached. The MSME is classified as mentioned below; (Ref Ministry of MSME Notification dated 26.06.2020)

**(i) Micro Enterprises:** Where the investment in plant and machinery or equipment does not exceed 1 crore rupees and turnover does not exceed 5 crore rupees,

**(ii) Small Enterprises:** Where the investment in plant and machinery or equipment does not exceed 10 crore rupees and turnover does not exceed 50 crore rupee,

**(iii) Medium Enterprises:** Where the investment in plant and machinery or equipment does not exceed 50 crore rupees and turnover does not exceed 250 crore rupees

Retail & Whole sale Traders: Any bidder who are retailer / Traders claim EMD / Bid security exemption shall refer Ministry OM 5/2(2)/2021-E/P&G/Policy dtd 02.07.2021 & 5/2(1)2020/E-P&G/Policy dtd 01.12.2020. The bidder whoever claim EMD / Bid security exemption through MSME certificate should classify themselves as above and need to provide details.

**Conditions for EMD / Bid Security:** EMD/ Bid security shall be returned / discharged to unsuccessful bidders within 30 days after finalization of the technically qualified bidders on technical bid evaluation.

#### **EMD may be forfeited:**

(a) If a bidder withdraws, modifies for provided unsolicited off involuntarily revising the price in what so every aspect, its bid during the period of bid validity specified by the bidder on the bid form; or

(b) In case of a successful bidder, fails to furnish order acceptance within 15days of the order and/or fails to furnish Performance Security.

EMD for a successful contractor shall be adjusted against performance security payable if submitted in DD/refunded if performance security is paid in full /performance security is submitted

**20. Conditional offers: Conditional offers** will not be accepted, and will not consider for evaluation.

**21. Signing of bids:** Each page of the tender document shall be digitally signed by the bidder and should be uploaded along with other documents.

**22. Acceptance of bids:** NIOT may accept or reject any / all bids including the lowest bid without assigning any reasons whatsoever.

**23. The compliance sheet** with reference to the specifications should be furnished against each parameter while submitting the bid/quotation, which is absolutely necessary. THE TENDERER SHALL SUBMIT TECHNICAL& COMMERCIAL COMPLIANCE SHEETS and BOQ (Price bid) separately ALONG WITH THEIR BID.TENDERS WITHOUT COMPLIANCE SHEETS WILL NOT BE EVALUATED. The Price bid should be unconditional.

**24. Canvassing:** Exerting pressure and/or offering in documenting any form by the bidder or by any other person on behalf of the bidder shall disqualify the bid and lead to its rejection of

bid/tender.

**25. Discounts:** Bidders are advised not to indicate separate discounts. Discounts, if any, offered should be duly considered and net rate quoted in the BOQ/Price Bid.

**26. Unrealistic bids:** with either cost which is impossible to achieve or for bidders who show that they are completely inexperienced or have completely inappropriate equipment will be rejected.

**27. Partial Delivery:** In general items/goods are to be delivered as per the delivery schedule in full quantity. In case if NIOT's request/ Bidder's convenience part supplies will be accepted only on issue of amendment to the order on the delivery schedule. Part supply without written order will not be accepted. However, payment will be effected as stipulated in LOI/Contract.

**28. Unsolicited Post-Tender Reduction:** The bidder shall note that any unsolicited post-tender reduction by them would disqualify them from participating in this as well as future tenders apart from forfeiting the EMD submitted or any other Bank Guarantee submitted.

**29. Modifications to Bids:** The Bidder shall not make any modifications to the bids after the closing date unless specifically requested for by NIOT. In case certain clarifications are sought by NIOT after opening of tenders, then the reply should be restricted to the clarification sought. Any bidder who modifies his bids (including a modification which has the effect of altering the value of his offer) after the closing date without any specific communication from NIOT shall make their tender as invalid and liable to be debarred from participation in future Tenders of NIOT as per rule.

#### **TERMS AND CONDITIONS GOVERNING THE BIDDERS**

**30. Currency of bids:**

**Firms outside India:** Bid should be DAP NIOT, Chennai basis. (For other conditions please refer Additional Terms & Conditions for Import) with Insurance covered from shipper's warehouse to consignee warehouse.

**31. Price:** The price shall include but not limited to

- a) Costs of goods/ services covered in this Contract.
- b) Taxes and duties
- c) Transportation and packing cost (Sea/Air worthy packing of internationally acceptable practices withstand transit and Transshipments by sea / air / road / rail)
- d) Cost of handling, documentation, freight, insurance from Contractor's warehouse up to NIOT warehouse, installation and commissioning of the equipment when part of Contractual obligation.
- e) Cost towards third party inspection as set forth in the Contract for LC mode of Payment. The Bidder shall indicate on the appropriate price schedule form, the unit prices and total bid prices of the goods proposes to supply under the Contract strictly as per price bid format of tender.

**32. Taxes and duties:** The IGST will be applicable as per HSN code, for the quotes in INR

**a) Customs Duty:** As per Notification No.51/96-(Customs) dated 23.7.1996; read with amendment Notification No.42/2022-customs dated 13<sup>th</sup> July,2022 withdrawing IGST exemption applies to



NIOT.NIOT is entitled for availing Concessional rate of Customs duty @24.49 %. Duty Exemption Certificate, wherever applicable, and as per rules will be issued upon receipt of order acceptance and specific request.

**b) Deduction of Indian Income Tax Deduction at Source applicable to foreign bidders:** Deductible for all the services rendered for India as per Indian Income Tax Act and Double Taxation Avoidance Agreement between the bidder's Country and the Government of India. The tax deduction at source will be @ 10.40% as per Income Tax Tariff of India or the rate as contained in the DTAA whichever is less, on production of a copy of the Tax Residency Certificate or Tax Identification Number. In case the Tax Residency Certificate or Tax Identification Number is not furnished, the Tax deduction at source will be 20.8% as per Indian Income Tax Act. However, the applicable taxes at the time of actual utilization of service, etc. will be deducted.

**33.Guaranteed time of delivery:** The time of delivery including design, testing, DNV certification and supply in satisfactory condition is the essence of the contract and the delivery schedule shall be as follows:

Supply, of all the In-line Cable Assemblies, Flanged/ Bulkhead Receptacles and all other items as mentioned in Table: 2 of SCC with DNV Certification/ approval for all the in-line Cable Assemblies and Receptacles - **within 9 months** from the date of signing of Contract.

**34.Deliverables:** Supply of all the In-line Cable Assemblies, Flanged/ Bulkhead Receptacles, Pressure rated dummy connectors and all the other items as mentioned in Table: 2 of Special Contract Conditions (SCC) with DNV Certification/ approval for all the in-line Cable Assemblies, Flanged/ Bulkhead receptacles and pressure rated dummy Connectors

**35.Extension of delivery period:** If the completion of systems / components is delayed for reasons of force majeure such as acts of God, Acts of Public enemy, acts of Government, fires, floods, epidemics, quarantine restrictions, illegal strikes and freight embargoes, the Contractor shall within 3 days from the date of such occurrence, give notice to NIOT in writing of his claim for extension of delivery period. NIOT on receipt of such notice may agree to extend the Contract delivery date as may be reasonable but without prejudice to other terms and conditions of the contract. Unless the extended delivery period is agreed by NIOT in writing, contractor cannot claim the extension of delivery time as a matter of right. NIOT shall have the right to either cancel/extend the order validity/ levy LD as appropriate.

**36.Delay in completion / Liquidated Damage (LD):**

If the Contractor fails to deliver the systems/ components within the time specified in the Contract, NIOT shall recover liquidated damages @ 0.5% of the item value per week of delay and maximum 5% of the item value. Essential components is not delivered shall deemed the entire system is delegated and ensuring the clarified for ensuring the total compliance as per tender specification and ensuring completion of entire system obligation as per the delivery schedule.

**37.Performance Security:** The successful bidders should deposit 5% of the LOI value as Performance Security within 2 weeks from the date of issue of LOI. The copy of the performance security should be submitted along with the LOI acceptance and the original to be sent through courier. The performance security shall be in one of the following forms:

(1) Insurance Surety Bonds,

(2) Account Payee Demand Draft (drawn in favour of "The Director N.I.O.T", Chennai in INR or in equivalent foreign currency).

(3) Fixed Deposit Receipt from any Commercial Bank.

(4) Bank Guarantee from any of the Commercial Banks.

(5) Online payment in an acceptable form.

Performance security shall be forfeited in the event of breach of Contract by the Contract in terms of the Contract. If Performance Security is not paid within the specified time, NIOT reserves its right to cancel the LOI and forfeit the EMD /Bid security.

Bank Guarantee shall be as per prescribed format as per NIOT and valid for 60 days beyond the scheduled delivery / completion period as per LOI / Contract.

**38. Performance/Warranty Bank Guarantee:** Performance/Warranty bank guarantee of 10% of the contract value should be provided and it should be valid throughout the warranty period. Performance Bank Guarantee should be from any Nationalized/Commercial bank in India or their branches outside India. Then 100% payment will be released. In case the performance bank guarantee is not provided, 90% payment will be released and balance 10% will be released after completion of the warranty period. If performance bank guarantee is submitted, bidders should clearly mention their acceptance to this effect in their quote.

**39. Payment:** 90 % payment will be made after receipt and acceptance of the all the items as mentioned in Table. 2 of SCC at NIOT within 30 days from the date of receipt of complete invoice along with the required DNV certification/ approval documents, warranty certificate, test certificates etc., The balance 10% will be paid after completion of the warranty period. If the contractor provides equivalent value of BG (10 %) valid for the entire warranty period, 100 % payment will be made after receipt and acceptance of the all the items along with all the documents as mentioned above

**40. Risk Purchase:** If the Contractor fails to deliver the stores or any instalment thereof within the period fixed for such delivery or at any time repudiates the Contract before expiry of such period, NIOT is entitled to cancel the Contract and source remaining items from any parties the stores not delivered at the risk and cost of the defaulting Contractor. No payment claimed for any part supplies made.

**41. Warranty:** The Contract warrants that the Goods supplied under this Contract are new, unused, of the most recent or current models and those they incorporate all recent improvements in design and materials unless provided otherwise in the Contract. The contractor further warrants that all Goods supplied under this Contract shall have no defect arising from design, materials or workmanship or from any act or omission of the contractor that may develop under normal use of the supplied Goods in the conditions prevailing in the country of final destination. This warranty should be minimum for the period for 12 months after acceptance of item. The warranty certificate should be furnished in the prescribed format available on the NIOT web site at the link <https://www.niot.res.in/index.php/vendor/login> in the Contractor letter head. If the Manufacturer standard warranty is more than 12 months the same shall be extended to NIOT without any restriction whatsoever. NIOT shall promptly notify the Contractor in writing of any claims arising under this warranty. Upon receipt of such notice, the Contractor shall, with all reasonable speed, repair or replace the defective Goods or parts thereof, without cost to NIOT other than, where applicable, the cost of inland delivery of

the repaired or replaced Goods or parts from ex- works or ex-factory or ex-showroom to the final destination. If the Contractor, having been notified, fails to remedy the defect(s) within a reasonable period, NIOT may proceed to take such remedial action as may be necessary, at the Contractor's risk and expense and without prejudice to any other rights which NIOT may have against the Contractor under the Contract. Also, such failure shall lead to suspension of vendor from participation as deem fit by NIOT.

**42. Defect Liability clause:** Any defect, or any other faults for plant components etc., which may appear against the set quality or performance characteristics within the Defects Liability period (DLP), of 12 months., any defects, arising in the opinion of the NIOT from materials or workmanship not in accordance with the contract, shall on demand which shall be made within the defects liability period, in writing by the NIOT and within such reasonable time as shall be stated therein specifying the work, materials or articles complained of notwithstanding that the same may have been passed or/and certified, paid for be amended and made good by the contractor. In case of default, NIOT may employ and pay other person or persons to amend and make good all such defects or other faults and all damages, losses and expenses consequent thereon or incidental there to. Contractor shall be made good and borne by the Contractor at the risk and cost of the contractor. And recoverable from the contractor by the NIOT or may be deducted by NIOT from any moneys due or that may become due to the contractor. Should any defective work have been done or materials supplied by the contractor or their associates the contractor shall be liable to make good the same in the same manner as if such work or materials had been subject to the provisions. Any delay in rectifying the defects within a maximum time of one month shall result in automatic extension of DLP within contract price to the extent of delay in rectification.

**43. Force Majeure:** For purposes of this Clause, "Force Majeure" means an event beyond the control of the Contractor and not involving the Contractor's fault or negligence and not foreseeable. Such events may include, but are not limited to, acts of NIOT either in its sovereign or Contractual capacity, wars or revolutions, fires, floods, epidemics, quarantine restrictions and freight embargoes.

If a Force Majeure situation arises, the bidder shall promptly notify NIOT in writing of such conditions and the cause thereof. Unless otherwise directed by NIOT in writing, the Contractor shall continue to perform its obligations under the Contract as far as is reasonably practical, and shall seek all reasonable alternative means for performance not prevented by the Force Majeure event.

**44. Arbitrations/Disputes:**

In the event of any dispute, difference, interpretation or application relating to this agreement arises; the same shall be settled amicably by the parties. In case the dispute or differences could not be settled amicably, the same shall be referred for adjudication through arbitration by an arbitrator to be appointed by the Director, NIOT with mutual consent.

The Indian Arbitration shall be concluded in accordance with the provisions of Arbitration & Conciliation Act, 1996 or any statutory modifications or re-enactment thereof and the rules made there under and for the time being in force shall apply to the arbitration proceedings.

Venue of such arbitration shall be at Chennai in India. The language of arbitration proceedings shall be English. The Arbitrator shall make reasoned award (the "award"), which shall be final and binding on the parties. The cost of the arbitration shall be shared equally by the parties to the contract. However, expenses incurred by each party in connection with the preparation, presentation etc., shall be borne by each party.

**45. Authorisation:** The bidder is qualified only if they are the OEM/dealer authorized by the OEM for the particular product or an Indian agent bidding on behalf of the OEM. For dealer/Indian agent, authorization letter from OEM is mandatory. In case of agent, the agency agreement should be provided along with the roles and responsibility. Indian Agent consideration shall be in conformance with Govt. of India directives. The Indian Agent shall quote on behalf of their OEM and IAC should be indicated in Percent (%) in the unpriced BOQ.

**46. SUBMISSION OF TECHNICAL DOCUMENT:** Specifications are basic essence of the product. The broad configuration / specification of the proposed purchase are given in NIT the Special Conditions of the contract (SCC). It must be ensured that the offers are strictly as per our specifications as mentioned in the Annexure - I of NIT(SCC). At the same time, it must also be kept in mind that merely copying our specifications in their quotation shall not make firms eligible for consideration. Technically unsuitable offers and offers not confirming to tender schedule shall be rejected.

a. The bidder is required to provide their comments item-by-item on the compliance sheet provided in the Annexure - I of NIT (SCC). Wherever the specified parameter is required within a range, the calculated/ estimated value as per the vendor's design is to be provided in the "Remarks" column. Deviations/exceptions, if any, from the specifications to be recorded in the "Remarks" column.

b. Offer must contain all relevant technical details. Relevant preliminary drawings (if any) pertaining to the quoted designs, duly signed by the authorized official shall be sent along with the quotation. Wherever mentioned, documentary evidence has to be enclosed in the quotation. Any erasures / over writing shall be counter signed by the person who is signing the bid. Any interlineations, erasures or overwriting shall be valid only if the person or persons signing the bid sign them.

NIOT will not provide any test procedures. All relevant required tests as mentioned in the technical specification to conduct within the quote price.

**47. Agents/Agency Commission:** The Seller confirms and declares to the Buyer that the Seller has not engaged any individual or firm, whether Indian or foreign whatsoever, to intercede, facilitate or in any way to recommend to the Government of India or any of its functionaries, whether officially or unofficially, to the award of the Contract to the Seller; nor has any amount been paid, promised or intended to be paid to any such individual or firm in respect of any such intercession, facilitation or recommendation. The Seller agrees that if it is established at any time to the satisfaction of the Buyer that the present declaration is in any way incorrect or if at a later stage it is discovered by the Buyer that the Seller has engaged any such individual/ firm, and paid or intended to pay any amount, gift, reward, fees, commission or consideration to such person, party, firm or institution, whether before or after the signing of this Contract, the Seller will be liable to refund that amount to the Buyer. The Seller will also be debarred from entering into any Contract with the Government of India for a minimum period of five years. The Buyer will also have a right to consider cancellation of the contract either wholly or in part, without any entitlement or compensation to the Seller who shall in such an event is liable to refund all payments made by the Buyer in terms of the Contract along with interest at the rate of 2% per annum above

(i) Prime Lending Rate of State Bank of India for Indian bidders, and (ii) London Inter Bank Offered Rate (LIBOR) for the foreign bidders. The applicable rates on the date of opening of bid shall be

considered for this. The Buyer will also have the right to recover any such amount from any Contracts in vogue with the Government of India.

- a). Details of all Agents will be disclosed at the time of submission of offers and within two weeks of engagement of an Agent at any subsequent stage of procurement.
- b). The Seller is required to disclose termination of the agreement with the Agent, within two weeks of the agreement having been terminated.
- c). NIOT/MoES reserves the right to inform the Seller at any stage that the Agent so engaged is not acceptable where upon it would be incumbent on the Seller either to interact with NIOT/MoES directly or engage another Agent. The decision of NIOT/MoES on rejection of the Agent shall be final and be effective immediately.
- d). All payments made to the Agent 12 months prior to tender submission would be disclosed at the time of tender submission and thereafter an annual report of payments would be submitted during the procurement process or upon demand of the NIOT/MoES.
- e). The Agent will not be engaged to manipulate or in any way to recommend to any Functionaries of the Govt. of India, whether officially or unofficially, the award of the Contract to the Seller or to indulge in corrupt and unethical practices.
- f). The Contract with the Agent will not be a conditional Contract wherein payment made or penalty levied is based, directly or indirectly, on success or failure of the award of the Contract.
- g). On demand, the Seller shall provide necessary information/inspection of the relevant financial documents/information, including a copy of the Contract(s) and details of payment terms between the Seller and the Agent engaged by him.
- h). If the equipment being offered by the Seller has been supplied /Contracted with any organization, public/private in India, the details of the same may be furnished in the technical as well as commercial offers. The Sellers are required to give a written undertaking that they have not supplied/is not supplying the similar systems or subsystems at a price lower than that offered in the present bid to any other Ministry/Department of the Government of India and if the similar system has been supplied at a lower price, then the details regarding the cost, time of supply and quantities be included as part of the commercial offer. In case of non-disclosure, if it is found at any stage that the similar system or subsystem was supplied by the Seller to any other Ministry/Department of the Government of India at a lower price, then that vary price, will be applicable to the present case and with due allowance for elapsed time, the difference in the cost would be refunded to the NIOT, if the Contract has already been concluded OR The Seller confirms and declares in the Techno-Commercial bid that they have engaged an agent, individual or firm, for promotion of their product.

In such case, following details are to be submitted in the Techno-Commercial bid:

- a) Name of the Agent
- b) Agency Agreement between the Seller and the agent giving details of their Contract obligation
- c) PAN Number, name and address of bankers in India and abroad in respect of Indian agent
- d) The nature and scope of services to be rendered by the agent and
- e) Percentage of agency commission payable to the agent.

**Agency Commission Payment:** Indian Agency commission shall be paid as per prevalent guidelines of Govt. of India, which stipulates payment of agency commission generally after release of all other payments have been made to the OEM/ Principal in terms of the Contract. The agency commission payable to the Indian agents shall be normally five percent but not more than the percentage specified in the agency agreement.

#### **48. Fundamental Principle of Public Buying:**

- i) Any bidder from a country which shares a land border with India will be eligible to bid in this tender only if the bidder is registered with the Competent Authority.

ii) "Bidder" (including the term 'tenderer', 'consultant' or 'service provider' in certain contexts) means any person or firm or company, including any member of a consortium or joint venture (that is an association of several persons, or firms or companies), every artificial juridical person not falling in any of the descriptions of bidders stated hereinbefore, including any agency branch or office controlled by such person, participating in a procurement process.

iii) "Bidder from a country which shares a land border with India" for the purpose of this Order means: -

- a. An entity incorporated, established or registered in such a country; or
- b. A subsidiary of an entity incorporated, established or registered in such a country; or
- c. An entity substantially controlled through entities incorporated established or registered in such a country; or
- d. An entity whose beneficial owner is situated in such a country; or An India (or other) agent of such an entity; or
- e. A natural person who is a citizen of such a country; or
- f. A consortium or joint venture where any member of the consortium or joint venture falls under any or the above.

iv) The beneficial owner for the purpose of (iii) above will be as under:

1. In case of a company or Limited Liability Partnership, the beneficial owner is the natural person(s), who, whether acting alone or together, or through one or more juridical person, has a controlling ownership interest or who exercises control through other means.

a. "Controlling ownership interest" means ownership of or entitlement to more than twenty-five percent of shares or capital or profits of the company;

b. "Control" shall include the right to appoint majority of the directors or to control the management or policy decisions including by virtue of their shareholding or management rights or shareholders agreements or voting agreements

2. In case of a partnership firm, the beneficial owner is the natural person(s) who, whether acting alone or together, or through one or more juridical person, has ownership of entitlement to more than fifteen percent of capital or profits of the partnership;

3. In case of an unincorporated association or body of individuals, the beneficial owner is the natural person(s), who, whether acting alone or together, or through one or more juridical person, has ownership of or entitlement to more than fifteen percent of the property or capital or profits of such association or body of individuals;

4. Where no natural person is identified under (1) or (2) or (3) above, the beneficial owner is the relevant natural person who holds the position of senior managing official;

5. In case of a trust, the identification of beneficial owner(s) shall include identification

v). An agent is a person employed to do any act for another, or to represent another in dealings with third person

vi). The successful bidder(contractor) shall not be allowed to sub-contract works to any contractor from a country which shares a land border with India unless such contractor is registered with the competent authority.

**49. ASSIGNMENT AND SUBCONTRACTING:** The contract shall not assign the contract or any part thereof, or any benefit or interest therein or hereunder, nor assume a fresh partner or partners nor dissolve the partnership at present subsisting between them in reference to this Contract without a formal written request and approval by NIOT. Also, the Contract shall not assign the Contract or any part thereof, or any benefit or interest therein or hereunder, nor

assume a fresh partner or partners nor dissolve the partnership at present subsisting between them in reference to this Contract without a formal written request and approval by NIOT. Also, partnerships or third party vendors during Tender should not be altered without a written approval.

## **50. Eligible Bidders**

**a)** Bidders should not be associated, or have been associated in the past, directly or indirectly, with a firm or any of its affiliates which have been engaged by the Purchaser to provide consulting services for the preparation of the design, specifications, and other documents to be used for the procurement of the goods to be purchased under this Invitation of Bids.

b) The bidders who have been temporarily suspended or removed from the list of registered suppliers by the purchaser or banned from Ministry/country wide procurement shall be ineligible for participation in the bidding process.

## **51. Cost of Bidding**

The Bidder shall bear all costs associated with the preparation and submission of its bid, and "the Purchaser", will in no case be responsible or liable for these costs, regardless of the conduct or outcome of the bidding process.

## **Code of Integrity for Public Procurement**

The purchaser requires that the bidders, suppliers and Contracts observe the highest standard of ethics during the procurement and execution of such Contracts. In pursuit of this policy, the following are defined:

(i) Corrupt practice

The offering, giving, receiving, or soliciting, directly or indirectly, of anything of value to influence the action of a public official in the procurement process or in Contract execution.

(ii) Fraudulent practice

A misrepresentation or omission of facts in order to influence a procurement process or the execution of a Contract.

(iii) Collusive practice

Means a scheme of arrangement between two or more bidders, with or without the knowledge of the purchaser, designed to establish bid prices at artificial, non-competitive levels.

(iv) Coercive practice

Means harming or threatening to harm, directly or indirectly, persons or their property to influence their participation in the procurement process or affect the execution of a Contract.

(v) Anticompetitive practice

Any collusion, bid rigging or anti-competitive arrangement, or any other practice coming under the purview of the Competition Act, 2002, between two or more bidders, with or without the knowledge of the purchaser, that may impair the transparency, fairness and the progress of the procurement process or to establish bid prices at artificial, non-competitive levels 7

(vi) Conflict of interest

participation by a bidding firm or any of its affiliates that are either involved in the consultancy Contract to which this procurement is linked; or if they are part of more than one bid in the procurement; or if the bidding firm or their personnel have relationships or financial or business transactions with any official of purchaser who are directly or indirectly related to tender or execution process of Contract; or improper use of information obtained by the (prospective)

bidder from the purchaser with an intent to gain unfair advantage in the procurement process or for personal gain

(vii) Obstructive practice

materially impede the purchaser's investigation into allegations of one or more of the above mentioned prohibited practices either by deliberately destroying, falsifying, altering; or by concealing of evidence material to the investigation; or by making false statements to investigators and/or by threatening, harassing or intimidating any party to prevent it from disclosing its knowledge of matters relevant to the investigation or from pursuing the investigation; or by impeding the purchaser's Entity's rights of audit or access to information

c) The Purchaser will reject a proposal for award if it determines that the bidder recommended for award has, directly or through an agent, engaged in corrupt, fraudulent, collusive or coercive practices in competing for the Contract in question.

d) The bidders/suppliers should sign a declaration about abiding by the Code of Integrity for Public Procurement and submit it in the form as per Annexure-II along with bid documents. In case of any transgression of this code, the bidder is not only liable to be removed from the list of registered suppliers, but it would be liable for other punitive actions such as cancellation of Contracts, banning and blacklisting or action by Competition Commission of India, and so on.

e) Obligations for Proactive disclosures

i) The Purchaser as well as bidders, suppliers, Contractors and consultants, are obliged under Code of Integrity for Public Procurement to sue-moto proactively declare any conflicts of interest (coming under the definition mentioned above – pre-existing or as and as soon as these arise at any stage) in any procurement process or execution of Contract. Failure to do so would amount to violation of this code of integrity.

ii) The bidder must declare, whether asked or not in a bid document, any previous transgressions of such a code of integrity with any entity in any country during the last three years or of being debarred by any other Procuring Entity. Failure to do so would amount to violation of this code of integrity.

iii) To encourage voluntary disclosures, such declarations would not mean automatic disqualification for the bidder making such declarations. The declared conflict of interest would be evaluated and mitigation steps, if possible, taken by the purchaser.

f) Punitive Provisions

Without prejudice to and in addition to the rights of the Purchaser to other penal provisions as per the bid documents or Contract, if the Purchaser comes to a conclusion that a (prospective) bidder/supplier, directly or through an agent, has violated this code of integrity in competing for the Contract or in executing a Contract, the purchaser may take appropriate measures including one or more of the following:

i) If his bids are under consideration in any procurement:

i. Forfeiture or encashment of bid security;

ii. Calling off of any pre-Contract negotiations; and

iii. Rejection and exclusion of the bidder from the procurement process.

ii) If a Contract has already been awarded

i. Cancellation of the relevant Contract and recovery of compensation for loss incurred by the Purchaser;

ii. Forfeiture or encashment of any other security or bond relating to the procurement;

iii. Recovery of payments including advance payments, if any, made by the purchaser along with interest thereon at the prevailing rate.



g) Provisions in addition to above:

- i. Removal from the list of registered suppliers and banning/debarment of the bidder from participation in future procurements of the purchaser for a period not less than one year;
- ii. In case of anti-competitive practices, information for further processing may be filed under a signature of the Joint Secretary level officer, with the Competition Commission of India;
- iii. Initiation of suitable disciplinary or criminal proceedings against any individual or staff found responsible.

## **52.Amendment to Bidding Documents**

In order to allow prospective bidders reasonable time to take the amendment into account while formulating their bids, the Purchaser, at its discretion, may extend the due date for the submission of bids and host the changes on the e-wizard portal through a corrigendum.

## **53.Documents Establishing Goods' Eligibility and Conformity to Bidding Documents**

a) To establish the goods' eligibility, the documentary evidence of the goods and services eligibility shall consist of a statement on the country of origin of the goods and services offered which shall be confirmed by a certificate of origin at the time of shipment.

b) To establish the conformity of the goods and services to the specifications and schedule of requirements of the bidding document, the documentary evidence of conformity of the goods and services to the bidding documents may be in the form of literature, drawings and data, and shall consist of:

a) A detailed description of the essential technical and performance characteristics of the goods;

b) A list giving full particulars, including available sources and current prices, of spare parts, special tools, etc., necessary for the proper and continuing functioning of the goods during the warranty period following commencement of the use of the goods by the Purchaser in the Price- bid; and

c) An item-by-item commentary on the Purchaser's Technical Specifications demonstrating substantial responsiveness of the goods and services to those specifications or a statement of deviations and exceptions to the provisions of the Technical Specifications.

d) For purposes of the commentary to be furnished pursuant to above, the Bidder shall note that standards for workmanship, material and equipment, designated by the Purchaser in its Technical Specifications are intended to be descriptive only and not restrictive. The Bidder may substitute these in its bid, provided that it demonstrates to the Purchaser's satisfaction that the substitutions ensure substantial equivalence to those designated in the Technical Specifications.

## **54.Confidentiality**

a) Information relating to the examination, evaluation, comparison, and post qualification of bids, and recommendation of Contract award, shall not be disclosed to bidders or any other persons not officially concerned with such process until Award of the Contract. However, decisions taken during process of tender evaluation shall be hosted on e-wizard portal.

b) Any effort by a Bidder to influence the Purchaser in the examination, evaluation, comparison, and post qualification of the bids or Contract award decisions may result in the rejection of its Bid.

## **55. Contacting the Purchaser**

- a) No Bidder shall contact the Purchaser on any matter relating to its bid, from the time of the bid opening to the time the Contract is awarded.
- b) Any effort by a Bidder to influence the Purchaser in its decisions on bid evaluation, bid comparison or Contract award may result in rejection of the Bidder's bid.

### Post qualification

- c) In the absence of pre-qualification, the Purchaser will determine to its satisfaction whether the bidder that is selected as having submitted the lowest evaluated responsive bid is qualified to perform the Contract satisfactorily, in accordance with the criteria listed in the SCC of the NIT.
- d) The determination will take into account the Eligibility & Qualification criteria listed in the SCC of the NIT and it will be based upon an examination of the documentary evidence of the bidder's qualifications submitted by the bidder, as well as such other information as the Purchaser deems necessary and appropriate.
- e) An affirmative determination will be a prerequisite for award of the Contract to the Bidder. A negative determination will result in rejection of the Bidder's bid.

## **56. Bidder's right to question rejection**

A Bidder shall have the right to be heard in case he feels that a proper procurement process is not being followed and/or his tender has been rejected wrongly. Only a directly affected bidder can represent in this regard as under:

- a) Only a bidder who has participated in the concerned procurement process i.e. pre-qualification, bidder registration or bidding, as the case may be, can make such representation.
- b) In case pre-qualification bid has been evaluated before the bidding of Technical bids, an application for review in relation to the technical bid may be filed only by a bidder who has qualified in prequalification bid.
- c) In case technical bid has been evaluated before the opening of the financial bid, an application for review in relation to the financial bid may be filed only by a bidder whose technical bid is found to be acceptable.
- d) In case a Bidder feels aggrieved by the decision of the purchaser, he may then send his representation in writing to the Purchaser's address as indicated in Special Conditions of Contract (SCC) within 05 working days from the date of communication of the purchaser intimating the rejection for reconsideration of the decision by the purchaser.
- e) Following decisions of the purchaser in accordance with the provision of internal guidelines shall not be subject to review:
  - a) Determination of the need for procurement;
  - b) Selection of the mode of procurement or bidding system;
  - c) Choice of selection procedure;
  - d) Provisions limiting participation of bidders in the procurement process;
  - e) The decision to enter into negotiations with the L1 bidder;
  - f) Cancellation of the procurement process except where it is intended to subsequently re-tender the same requirements;
  - g) Issues related to ambiguity in Contract terms may not be taken up after a Contract has been signed, all such issues should be highlighted before consummation of the Contract by the vendor/Contractor; and Complaints against specifications except under

the premise that they are either vague or too specific so as to limit competition may be permissible.

**56. Joint Venture, Consortium or Association**

a) If the Supplier is in a joint venture, consortium, or association, all of the parties shall be jointly and severally liable to the Purchaser for the fulfilment of the provisions of the Contract and shall designate one party to act as a leader with authority to bind the joint venture, consortium, or association. The composition or the constitution of the joint venture, consortium, or association shall not be altered without the prior consent of the Purchaser.

b) **Amalgamation/Acquisition etc:**

In the event the Manufacturer/Supplier proposes for amalgamation, acquisition or sale its business to any firm during the Contract period, the Buyer/Successor of the Principal Company are liable for execution of the Contract and also fulfilment of Contractual obligations i.e. supply, installation, commissioning, warranty, maintenance/replacement of spares accessories etc. You may confirm this condition while submitting the bid.

**Terms and Conditions (Import)**

**57. Goods certificate:** To establish the goods' eligibility, the documentary evidence of the goods and services eligibility shall consist of a statement on the country of origin of the goods and services offered which shall be confirmed by a certificate of origin at the time of shipment.

**58. Documentary evidence:** Relevant literature pertaining to the items quoted such as specification sheet with drawings, handling and storage instructions (if any), routine maintenance instructions (if any), routine test instructions (if any) etc. has to be sent along with the quotation. Wherever the submission of documentary evidence (as proof of some parameter) is mentioned in the SCC, the same also has to be enclosed in the quotation.

**59. The import quotation** should be in DAP, (Delivery at place should be by Air Freight for light weight / low volume / fragile cargos and Sea freight for heavy weight / large volume cargo) **NIOT, Chennai**. Insurance should be arranged from SHIPPERS WAREHOUSE TO CONSIGNEE'S WAREHOUSE up to installation and commissioning of the equipment from reputed Insurance companies only for DAP value plus 10% or replacement value whichever is higher. NIOT shall be the beneficiary of Insurance Policy. Value of Cargo should be declared in the AWA / Bill of Lading for carriage purpose apart from Custom purpose. Sufficient care should be taken on packing and it should be sea worthy packing as per International standard. The quotation should exclusively specify FOB cost, insurance, Air/Sea freight element and local agency commission if any to be paid in Indian Rupees. The responsibility of customs clearance, payment of customs duty and inland transportation to NIOT will be done by NIOT. During evaluation of the price bid, Customs duty and clearance charges @25% shall be loaded to arrive the landed cost at NIOT.

**60. Import and Export Licenses**

**60.1** If the items are covered under restricted category of EXIM policy in India the bidder may intimate such information for obtaining necessary, license in India or Export licenses in the bidder country.

**60.2** If the ordered equipment is subject to Vendor procuring an export license from the designated government agency / country from where the goods are shipped / sold, the vendor has to mention the name, address of the government agency / authority. The vendor must also mention the time period within which the export license will be granted in normal course

**61. Currency of the bid:** Currency once quoted will not be allowed to change.

**62. Price comparison:** As per the selling exchange rates established by SBI Prevailing on the date of opening of price bid shall be applicable for the purpose of conversion of foreign currency for price comparison.

**63. Forex fluctuation:** Since bidders are permitted to quote in any currency and also receive payments in that currency, NIOT shall not compensate for any foreign exchange fluctuations. Also, there will be no loading of foreign exchange for deciding the inter-se- ranking of bidders in this tender.

**64. Bank charges:** All Bank charges inside India to NIOT account and all Bank charges outside India to supplier account.

**65. Dispatch of goods:** Please note that the dispatch of consignment should be made by Air/Sea freight and not through private courier service since this Institute is empowered to clear the consignments duty exemption from customs as R&D Institutions which will not be applicable for dispatches through private courier service. Any customs duty payable on account of mode of dispatch other than those specified will be to contractor account and the same will be debited / Adjusted from the dues payable to contractor. For low volume/low weight cargo, Govt. Postal services only to be utilized.

**66. Third Party Inspection:**

The Third-Party Inspection (for pre-shipment) is mandatory only for OEM direct execution and payment negotiated through Letter of credit. The Third-Party Inspection shall be conducted by DNV/SGS/Lloyds/TUV/ABS or any other IACS Agency. The inspection shall be either at airport point of loading or at the Suppliers factory before dispatch of cargo. Bidders are requested to mention the inspection charges explicitly in their quote. Third party inspection charges at actual will be reimbursed on submission of separate invoice for TPI charges (along with the inspection report and invoice issued by the third-party inspection agency) while furnishing the commercial invoice for supply. In the absence of separate invoice, tax deduction at source @10% of the quoted TPI charges will be deducted as per IT provision of Govt. of India.

b) The Third-Party Inspection is not mandatory for Indian bidders and for payment after supply and acceptance through Wire Transfer by foreign supplier and in INR to Indian Supplier/ Agent.

**67. Payment:** NO ADVANCE PAYMENT WILL BE MADE As per standard terms 90% payment for import will be made through Wire Transfer / Irrevocable Letter of Credit within 30days to be opened through our Banker after supply and acceptance of the item. If the mode of payment is through Irrevocable Letter of Credit, Third Party Inspection report is mandatory, so bidders are requested to mention the rates for TPI charges in the BOQ. Balance 10% will be released through wire transfer after completion of the warranty period. If PBG is submitted 100% payment will be released.

**68. Shipment:** Generally, Part shipment and Transshipment are not permitted. If required for, the bidder has to indicate the reason. All risk insurance should be taken, covering the entire shipment up to supply and acceptance of the item within the quoted price. Please indicate the Port of Shipment along with the country of origin of the Supply.

**69. Demurrage:** Demurrage Charges, if any, Payable on Account of Delay in Receipt of Advance Copies of Invoice / Shipment Documents will be debited to Your Account. In the absence of clear documentation, the cargo cannot be cleared and cargo will be kept uncleared and will lie at Bailee's premises at the risk and cost of contractor.

**70. Customs Clearance:**

1. All Bills of Entry must be filed with customs prior to arrival of the vessel or aircraft latest by next day of arrival of the vessel or aircraft. Failing which penalty of Rs.5000/- (approx. \$ 75) per day shall be levied by Indian customs for the delay of first three days.

2. Rs.10000/- (approx. \$150) per day shall be levied for delay in filling bill of entry beyond three days of arrival of the vessel or aircraft

3. This has come into effect on 31.03.2017.

4. Customs duty on bill of entry to be paid on the same day failing which penal interest payable on customs duty.

5. Free customs clearance period is reduced to 2 days from 3. Hence, it is requested to note this change and ensure that all/ complete documents (1. Airway bill, 2. Invoice copy 3. Packing List 4. Insurance Copy) at least 02 working days prior on the date of arrival of the shipment at Chennai airport so that bill entries are filed by NIOT. If any delay is attributable to the shipper on the above, the penalty/penal interest will be adjusted in shipper's invoice from due payment.

## **71. Termination of Contract by NIOT**

a) The contract shall become effective from the date of signing of contract and the contract shall automatically get terminated after successful completion of all contractual obligation and warranty obligation as per the terms of the contract.

b) (i) Termination of the contract due to breach of contract by the contractor

(ii) Termination of contract due to default,

(iii) Termination of the contract due to insolvency,

(iv) Termination of the contract for convenience.

If the termination of the contract happens due to the above factors, [(i), (ii) &(iv)] initially the written notice will be issued within 30 days to settle the issue on mutually agreed terms with mutual consent.

Else, the matter will be referred to the Mediators (IEMs) for their advise /settlement. If the settlement is not fruitful the parties can proceed for arbitration as per the clause No.43.

During this process the contract will be in live and continue to be live till the termination notice is issued.

If the contract is terminated due to the any factors above, except (iii) depending on the merit of the case, the contractor shall be suitably compensated and mutual agreed terms for terminating the contract shall be arrived with the consent of IEMs.

## **72. Conflict of Interest**

(1) An Applicant shall not have a conflict of interest that may affect the Selection Process or the Consultancy (the "Conflict of Interest"). Any Applicant found to have a Conflict of Interest shall be disqualified. In the event of disqualification, the NIOT/ Authority shall forfeit and appropriate the Bid Security as mutually agreed genuine pre-estimated compensation and damages payable to the NIOT/Authority for, *interalia*, the time, cost and effort of the NIOT/Authority including consideration of such Applicant's Proposal, without prejudice to any other right or remedy that may be available to the NIOT / Authority here under or otherwise.

(2) The NIOT/Authority requires that the Consultant provides professional, objective, and impartial advice and at all times hold the NIOT/Authority's interests paramount, avoid conflicts with other assignments or its own interests, and act without any consideration for future work. The Consultant shall not accept or engage in any assignment that would be in conflict with its prior or current obligations to other clients, or that may place it in a position of not being able to carry out the assignment in the best interests of the NIOT / Authority

(i)An Applicant shall be deemed to have a Conflict of Interest affecting the Selection Process, if the applicant, its consortium member the "Member") or Associate (or any constituent thereof)and any other Applicant, its consortium member or Associate(or any constituent thereof) have common controlling shareholders or other ownership interest; provided that this disqualification shall not apply in cases where the direct or indirect shareholding or ownership interest of an Applicant, its Member or Associate (or any shareholder thereof having a shareholding of more than 5 percent of the paid up and subscribed share capital of such Applicant, Member or Associate, as the case may be) in the other Applicant, its consortium member or Associate is less than 5% (five percent)of the subscribed and paid up equity share Capital thereof; provided further that this disqualification shall not apply to any ownership by a bank, insurance company, pension fund or a public financial institution referred to in section 4A of the Companies Act, 1956. For the purposes of this Clause13.1(c)(i), in direct shareholding held through one or more intermediate persons shall be computed as follows:(aa) where any intermediary is controlled by a person through management control or otherwise, the entire shareholding held by such controlled intermediary in any other person (the "Subject Person")shall be taken into account for computing the shareholding of such controlling person in the Subject Person; and (bb) subject always to sub-clause (aa)above, where a person does not exercise control over an intermediary, which has shareholding in the Subject Person, the computation of in direct shareholding

of such person in the Subject Person shall be undertaken on a proportionate basis; provided, however, that no such shareholding shall be reckoned under this sub- clause (bb) if the shareholding of such person in the intermediary is less than 26% (twenty six percent) of the subscribed and paid up equity shareholding of such intermediary; or

(ii) A constituent of such Applicant is also a constituent of another Applicant; or

(iii) Such Applicant or its Associate receives or has received any direct or indirect subsidy or grant from any other Applicant or its Associate; or

(iv) Such Applicant as the same legal representative for purposes of this Application as any other Applicant; or

(v) Such Applicant has a relationship with another Applicant, directly or through common third parties, that puts them in a position to have access to each other's information about, or to influence the Application of either or each of the other Applicant; or

(vi) There is a conflict among this and other consulting assignments of the Applicant (including its personnel and Sub-consultant) and any subsidiaries or entities controlled by such Applicant or having common controlling shareholders. The duties of the Consultant will depend on the circumstances of each case. While providing consultancy services to the NIOT/ Authority for this particular assignment, the Consultant shall not take up any assignment that by its nature will result in conflict with the present assignment; or

(vii) A firm which has been engaged by the NIOT/Authority to provide goods or works or Services for a project, and its Associates, will be disqualified from providing consulting services for the same project, conversely, a firm hired to provide consulting services for the preparation or implementation of a project, and its Members or Associates, will be disqualified from subsequently providing goods or works or services related to the same project.

**73. Shipping Instructions:** If Seller uses wood packaging materials such as pallets, crates, boxes, dunnages, cases, skids and pieces of wood used to support or brace cargo being imported into India, it shall be heat treated or fumigated with methyl bromide in accordance with EPA label instructions and include a mark that certifies the wood completed the required treatment under the guidelines for Regulating Wood Packaging Material in International Trade, "ISPM 15 of the International Standards of Phytosanitary Measures (ISPM) and any associated amendments, revisions or exemption identified by the Regional Plant Quarantine Station, Chennai, India. LOI/Contract number(s) must appear on all correspondence, shipping labels, and shipping documents, including all packing sheets, and invoices. All pallets must be shrink-wrapped or banded

#### **74. Clarifications**

Applicants requiring any clarification on the RFP may send their query by email to [hvt@niot.res.in](mailto:hvt@niot.res.in) before the tender closing date. The Authority will post the reply to all such queries on the NIC CPP Portal and NIOT Website. All bidders shall visit official NIC CPP portal before uploading of their bid to take note of the changes / corrigendum issued.

The authority reserves the right not to respond to any questions or provide any clarifications, in its sole discretion, and nothing in this RFP shall be construed as obliging the Authority to respond to any question or to provide any clarification.

#### **75. Indemnities**

The Contractor hereby agrees to indemnify and hold harmless NIOT and its Director, officers and employees, from and against any and all suits, losses, liabilities, damages, claims, settlements, costs and expenses, including reasonable attorneys' fees, based on or arising, directly or indirectly, from:

- i. Breach of this Agreement by the Contractor
- ii. Not performing the Scope of Work or any other obligation under this Agreement or Tender in accordance with the provisions and schedules of this Agreement or the Tender
- iii. Violation or contravention of any Legislation on the part of the Contractor
- iv. Any negligence or wilful misconduct of Contractor, which violates any provision of this Agreement
- v. Infringement of any intellectual property belonging to any third party by the Contractor
- vi. Any breach of an agreement or understanding between Contractor and any and all Third Parties due to which a liability arises on NIOT
- vii. Any claim that any representations or warranties contained herein are not true or any breach thereof
- viii. Any loss or damage caused by the Contractor to NIOT, its personnel or property
- ix. Any loss or damage caused by the Contractor to any and all Third Parties for which a claim against NIOT has arisen
- x. Breach, expiry, cancellation, revocation or invalidity of any and all licenses, permits, authorizations and registrations which the Contractor is required to obtain, keep valid and comply with under any Legislation in order to perform its obligations hereunder
- xi. Any obligation of the Contractor performed by NIOT under this Agreement or under any Legislation.

## **76. Preference to Make in India**

As per DPIIT Order No. P-45021/2/2017-PP (BE-II) dated 16th September 2020 issued by Ministry of Commerce, Class-I and Class-II Local suppliers are eligible to bid (as specified in Clause- 1.30.3).

### **I. Definitions of terms applicable to Make in India procurement policy of Govt of India: -**

- a) 'Local content ' means the amount of value added in India which shall be the total value of the item procured (excluding net domestic indirect taxes) minus the value of imported content in the item (including all customs duties) as a proportion of the total value, in percent.
- b) 'Class-I Local supplier' means a supplier provider whose product offered for procurement meets the local content of 50% and above.
- c) 'Class-II Local supplier' means a supplier provider whose product offered for procurement meets the local content of 20% and above but less than 50%.
- d) 'Non-Local supplier' means a supplier provider whose product offered for procurement meets the local content of less than 20%.
- e) 'L1' means the lowest tender or lowest bid or the lowest quotation received in this tender, bidding process or other procurement solicitation as adjudged in the evaluation process as per the tender or other procurement solicitation.
- f) 'Margin of purchase preference ' means the maximum extent to which the price quoted by a local supplier may be above the L1 for the purpose of purchase preference.

### **II. Purchase preference: -**

- a) Among all qualified bids, the lowest bid will be termed as L1. If L1 is from a Class-I local supplier, the contract for full quantity will be awarded to L1.
- b) If L1 bid is not from a Class-I local supplier, 50% of the order quantity shall be awarded to L1. Thereafter, the lowest bidder among the Class-I local suppliers, will be invited to match the L1 price for the remaining 50% quantity subject to the local supplier's quoted price falling within the margin of purchase preference, and contract for that quantity shall be awarded to such Class-I local supplier subject to matching the L1 price. In case such lowest eligible Class-I local supplier fails to match the L1 price or accepts less than the offered quantity, the next higher Class-I local supplier within the margin of purchase preference shall be invited to match the L1 price for remaining quantity and so on, and

contract shall be awarded accordingly. In case some quantity is still left uncovered on local suppliers, then such balance quantity may also be ordered on the L1 bidder.

c) In the procurements of goods or works, which are covered by para 3(b) or reference order and which are not divisible in nature, and in procurement of services where the bid is evaluated on price alone, the 'Class-I local supplier' shall get purchase preference over 'Class-II local supplier' as well as 'Non-local supplier', as per following procedure:

(i) Among all qualified bids, the lowest bid will be termed as L1. If L1 is from a Class-I local supplier, the contract will be awarded to L1.

(ii) If L1 is not from a Class-I local supplier, the lowest bidder among the Class-I local suppliers, will be invited to match the L1 price subject to local supplier's quoted price falling within the margin of purchase preference, and the contract shall be awarded to such Class-I local supplier subject to matching the L1 price.

(iii) In case such lowest eligible Class-I local supplier fails to match the L1 price, the Class-I local supplier with the next higher bid within the margin of purchase preference shall be invited to match the L1 price and so on and contract shall be awarded accordingly. In case none of the Class-I local suppliers within the margin of purchase preference matches the L1 price, then the contract may be awarded to the L1 bidder.

(iv) Only Class-II Local suppliers are not eligible to get price preference in any procurement undertaken by procuring entities.

### **III. Applicability in tenders where contract is to be awarded to multiple bidders: -**

In tenders where contract is awarded to multiple bidder's subject to matching of L 1 rates or otherwise, the 'Class-I local supplier' shall get purchase preference over 'Class-II local supplier' as well as 'Non-local supplier', as per following procedure:

a) In case there is sufficient local capacity and competition for the item to be procured, as notified by the nodal Ministry, only Class I local suppliers shall be eligible to bid. As such, the multiple suppliers, who would be awarded the contract, should be all and only 'Class I Local suppliers'.

b) In other cases, 'Class II local suppliers' and 'Non-local suppliers' may also participate in the bidding process along with 'Class I Local suppliers' as per provisions of this Order. c) If 'Class I Local suppliers' qualify for award of contract for at least 50% of the tendered quantity in any tender, the contract may be awarded to all the qualified bidders as per award criteria stipulated in the bid documents. However, in case 'Class I Local suppliers' do not qualify for award of contract for at least 50% of the tendered quantity, purchase preference should be given to the 'Class I local supplier' over 'Class II local suppliers'/ 'Non local suppliers' provided that their quoted rate falls within 20% margin of purchase preference of the highest quoted bidder considered for award of contract so as to ensure that the 'Class I Local suppliers' taken in totality are considered for award of contract for at least 50% of the tendered quantity.

d) First purchase preference has to be given to the lowest quoting 'Class-I local supplier', whose quoted rates fall within 20% margin of purchase preference, subject to its meeting the prescribed criteria for award of contract as also the constraint of maximum quantity that can be sourced from any single supplier. If the lowest quoting 'Class-I local supplier', does not qualify for purchase preference because of aforesaid constraints or does not accept the offered quantity, an opportunity may be given to next higher 'Class-I local supplier', falling within 20% margin of purchase preference, and so on.

e) To avoid any ambiguity during bid evaluation process, the procuring entities may stipulate its own tender specific criteria for award of contract amongst different bidders including the procedure for purchase preference to 'Class-I local supplier' within the broad policy guidelines stipulated in sub-paras above.

### **IV. Minimum local content: -**

The 'local content' requirement to categorize a supplier as 'Class-I local supplier' is minimum 50%. For 'Class-II local supplier', the 'local content' requirement is minimum 20%. Nodal Ministry/ Department



may prescribe only a higher percentage of minimum local content requirement to categorize a supplier as 'Class-I local supplier'! 'Class-II local supplier'. For the items, for which Nodal Ministry! Department has not prescribed higher minimum local content notification under the Order, it shall be 50% and 20% for 'Class-I local supplier'! 'Class-II local supplier' respectively.

**V. Verification of Local content: -**

- a. The 'Class-I local supplier'! 'Class-II local supplier' at the time of tender, bidding or solicitation shall be required to indicate percentage of local content and provide self-certification that the item offered meets the local content requirement for 'Class-I local supplier'! 'Class-II local supplier', as the case may be. They shall also give details of the location(s) at which the local value addition is made.
- b. In cases of procurement for a value in excess of Rs. 10 crores, the 'Class-I local supplier'! 'Class-II local supplier' shall be required to provide a certificate from the statutory auditor or cost auditor of the company (in the case of companies) or from a practicing cost accountant or practicing chartered accountant (in respect of suppliers other than companies) giving the percentage of local content.
- c. False declarations will be in breach of the Code of Integrity under Rule 175(1)(i)(h) of the General Financial Rules for which a bidder or its successors can be debarred for up to two years as per Rule 151 (iii) of the General Financial Rules along with such other actions as may be permissible under law.

**VI. Manufacture under license/ technology collaboration agreements with phased indigenization: -**

While notifying the minimum local content, Nodal Ministries may make special provisions for exempting suppliers from meeting the stipulated local content if the product is being manufactured in India under a license from a foreign manufacturer who holds intellectual property rights and where there is a technology collaboration agreement / transfer of technology agreement for indigenous manufacture of a product developed abroad with clear phasing of increase in local content.

**VII. Classification of MSE'S: -**

- (i) Micro Enterprises: Where the investment in plant and machinery or equipment does not exceed 1 crore rupees and turnover does not exceed 5 crore rupees,
- (ii) Small Enterprises: Where the investment in plant and machinery or equipment does not exceed 10 crore rupees and turnover does not exceed 50 crore rupees,
- (iii) Medium Enterprises: Where the investment in plant and machinery or equipment does not exceed 50 crore rupees and turnover does not exceed 250 crore rupees
- (iv) Retail & Whole sale traders: Any bidder who are retailer/ Traders claim EMD/ Bid security exemption shall refer Ministry OM 5/2(2)/2021-E/P&G/Policy dtd 02.07.2021 & 5/2(1)2020/E-P&G/Policy dtd 01.12.2020.

**VIII. Price Preference to MSEs: -**

- a) Among the qualified bids, the lowest bid will be termed as L1, If L1 is class 1 local supplier the contract will be awarded to L1.
- b) In tender, participating Micro and Small Enterprises quoting price within price band of L1 + 15% shall also be allowed to supply a portion of requirement by bringing down their price to L1 price in a situation where L1 price is from someone other than a Micro and Small Enterprise and such Micro and Small Enterprise shall be allowed to supply upto 25 percent of the total tendered value, The 25(twenty five)% quantity is to be distributed proportionally among these bidders, in case there are more than one MSME's within such price band.
- c) In case the tendered quantity of goods cannot be split/ divided MSE quoted price within the band L1+15% may be awarded for full complete supply of total tendered value to MSE.
- d) MSEs participating in the tender must submit valid & authorised copy of certificate of registration with any one of the above agencies. In case of bidders submitting DIC registration certificate shall attach

original notarised copy of the DIC certificate.

e) The MSE's Bidder to note and ensure that nature of services and goods/items manufactured mentioned in MSE's certificate matches with the nature of the services and goods /items to be supplied as per Tender.

f) The registration certificate issued from any one of the above agencies must be valid as on Bid closing date of the tender. Bidder shall ensure validity of registration certificate in case bid closing date is extended.

g) The MSEs who have applied for registration or renewal of registration with any of the above agencies / bodies, but have not obtained the valid certificate as on close date of the tender, are not eligible for EMD exemption / preference.

h) Where any aggregator has been appointed by the Ministry of MSE, themselves quote on behalf of some MSE units, such offers will be considered as offer from MSE units and all such facilities would be extended to these aggregators also.

**Section I Commercial Terms Compliance sheet (To be filled by bidder)**

<b>S. No</b>	<b>Particulars</b>	<b>Yes</b>	<b>No</b>	<b>Page Ref</b>
1	Whether EMD for <b>INR 4,54,000/- or USD5450.52/-</b> scanned and uploaded along with the technical document?			
2	Whether every page of the tender document is digitally signed and uploaded in the cpp portal along with the other documents.			
3	Whether Taxes and duties are shown separately in the quote. (Registration numbers for claiming the same to be strictly indicated and the copy of the certificates enclosed)			
4	Whether accepted to submit the LOI acceptance within 15 days from the date of receipt of the LOI?			
5	Whether submission of 5% of the contract value as Performance/warranty Security is acceptable?			
6	Whether submission of 10% of the supply value as Performance warranty Bank Guarantee is acceptable?			
7	Whether quote is valid for 120 days from the date of tender opening or time specified in the tender document whichever is later?			
8	Whether payment terms of the tender is complied with?			
9	Whether INCOTERM DAP NIOT Chennai is complied with?			
10	Whether the tender is fully complying with tender specification / Adjustment if no, list out deviations very clearly along with the appropriate reason for the deviation?			
11	Whether item-wise price is quoted as per price bid and quoted price is realistic?			
12	Whether liquidated damage as specified in the NIT accepted unconditionally?			
13	Whether the delivery period of six month is acceptable as per the tender.			
14	Whether the warranty period (minimum 12 months) is acceptable as per the tender.			
15	Bidder is responsible for all performance benchmarks and the quote should contain an undertaking certifying the same.			
16	Whether integrity pact is signed by authority signatory and uploaded			
17	Whether Past track record of quality and service is enclosed?			
18	In case of Dual Bid whether unpriced/blank commercial bid (Part-B) is enclosed in part – A (Technical Bid)?			
19	Whether list of deliverables attached and comply as per tender?			

## Section II Technical Compliance Sheet

S. No	Description	Specification	Compliance (Yes/ No)	Remarks
11.1	Technical Pre-qualification Criteria (Common for all Groups)	The Bidder or the corresponding OEM (in case the bidder is not the OEM for the Cable assemblies and Connectors) shall have manufactured/ supplied Underwater Cable assemblies / Connectors rated for greater than or equal to 6000 m water depth at least once during the last 10 years, year ending 31.03.2024.		
11.2	Proof of fulfilment of technical pre-qualification Criteria	Proof of execution/ supply such as copies of delivery acceptance/ copy of purchase order completion certificate/ Third party inspection report for past shipments by authorized certifying agency/ testimonials from past clients etc. to be submitted. Absence/ non-submission of documentary evidence as any of the above may lead to tender being non-responsive/ invalid.		
11.3	Composition of each cable assembly and connector set	In-line cable assembly with Cable Connector Plug (CCP) at both the ends. The CCP at one end shall be Male and the other end shall be Female. Suitable mating Flanged/ Bulkhead Connector Receptacles (FCRs/ BCRs) with pigtailed for both the CCPs. Pressure rated dummy connectors for the FCRs/ BCRs. Dust caps for all the CCPs and FCRs/ BCRs.		
11.4	Nominal pressure of components (P <sub>N</sub> )	All the in-line cable assemblies and FCRs/ BCRs are required for Manned Submersible application having nominal diving depth (NDD) of 6000 m. The nominal pressure of components (PN) = 606 bar.		
11.5	Material of construction for the Connector and Flanged/ Bulkhead receptacle body	<b>Titanium alloy Grade. 5</b>		

11.6	Mounting Requirement for FCRs/ BCRs	All the Flanged/ Bulkhead receptacles (FCRs/ BCRs) are intended to be mounted on Dry pressure cases and shall have suitable provision for mounting on a base plate of thickness 65 mm (approximate). The BCRs (if proposed) shall have the provision of either screwing it directly to the flange or tightening it with lock nut from the pigtail end. Exact thickness of the mounting base plate will be communicated to the successful bidder/s during the placement of Purchase order/ Contract.		
11.7	Locking Arrangement	All the Inline cable assemblies, Flanged/ bulkhead receptacles and pressure rated dummies shall be provided with <b>proper locking arrangement</b> to hold the mating part tightly in mated condition.		
11.8	Locking Sleeves	Required locking sleeves (if used) shall be included along with the Inline Cable assemblies, Flanged/ Bulkhead Receptacles and Pressure rated Dummy Connectors.		
11.9	Dust caps	Suitable dust caps shall be provided for all CCPs and FCRs/ BCRs to avoid dust entry during storage.		
11.10	Operating Temperature	0 to + 55°C or better		
11.11	Operating Voltage	200 V DC (Maximum)		
11.12	Length of Inline cable assemblies	Length of Inline cable assemblies may vary by $\pm 1$ m. Exact length required for each cable assembly will be communicated to the successful bidder during the placement of Purchase order/ Contract.		
11.13	Requirements of O-Rings	All the O-Rings required for the Connectors, FCRs/ BCRs shall be included in the supply. One extra set of O-Ring shall be provided.		
11.14	Pigtail length for flanged/ bulkhead receptacles	All the flanged/ bulkhead receptacles shall be provided with 1.5 m long pigtails.		
11.15	Connection between CCPs in cable assemblies	For all the cable assemblies, the connection between the CCPs is one-to-one.		
11.16	Testing and DNV Certification/ approval	For all the Cable assemblies and Connectors, the testing as per DNV requirements shall be carried out in the presence of DNV surveyor and certification/ approval for usage in manned underwater vehicle application for		

		the Nominal Diving Depth (NDD) of 6000 m shall be obtained. Gas tightness test need not be conducted.		
11.17	Classification rules to be followed	The testing of underwater Cable assemblies and flanged/ bulkhead receptacles shall be in accordance with the DNV rules for classification of Manned Submersibles Edition July 2019. For all hydraulic pressure tests, $P_N = 606$ bar.		
11.18	Witnessing of tests by NIOT	NIOT may depute its representative to witness the tests (Necessary expenditure will be borne by NIOT).		
11.19	Scope of testing and DNV certification/ approval	The testing and DNV certification/ approval is the scope of the successful bidder. NIOT may depute its representatives to witness the tests. Necessary expenditure for the same will be borne by NIOT.		
11.20	Test Procedures	Test procedures may be devised by the successful bidder on consultation with DNV. NIOT will not provide any test procedure.		
11.21	Testing and DNV Certification/ approval charges	Testing and DNV certification/ approval charges shall be quoted separately in "lumpsum" in the BOQ and not in man hours/ daily rates. The testing charges quoted shall be inclusive of the cost of production of test pieces, fixtures etc.		
11.22	Forwarding of DNV approved drawings	Before the start of production of cable assemblies and connectors, the successful bidder shall obtain approval from DNV and the approved design/ fabrication/ schematic drawings shall be forwarded to NIOT for reference.		
11.23	Additional tests	The successful bidder is free to conduct any other test in addition to those mentioned in DNV rules as part of their FAT within the quoted price and no additional claim will be considered.		
11.24	Discarding/ destroying of samples	All the test pieces/ samples used for <b>type testing</b> shall be discarded/ destroyed after the tests and shall not form part of the supply.		

### Section III: Scope of Supply:

Sl no	Description	Quantity (Nos)
1	In-line cable assembly of length 3 m with Male Connector (CCP) at one end and Female Connector (CCP) at the other end as per the technical requirements.	8
2	In-line cable assembly of length 6 m with Male Connector (CCP) at one end and Female Connector (CCP) at the other end as per the technical requirements.	8
3	Suitable mating Flanged/ Bulkhead receptacle (FCR/ BCR) male pins with 1.5 m long pigtails, suitable for the Female Connectors mentioned in Sl.no 1 & 2.	16
4	Suitable mating Flanged/ Bulkhead receptacle (FCR/ BCR) female pins with 1.5 m long pigtails, suitable for the male Connectors mentioned in Sl.no 1 & 2.	16
5	Pressure rated Dummy Connectors for the Flanged/ Bulkhead receptacles mentioned in Sl.no 3.	4
6	Pressure rated Dummy Connectors for the Flanged/ Bulkhead receptacles mentioned in Sl.no 4.	4

**Section IV: Un Price Bid format**

<b>Sl no</b>	<b>Description</b>	<b>Quantity (Nos)</b>	<b>Rate per Unit</b>	<b>Quoted Currency</b>	<b>Amount</b>
1	In-line cable assembly of length 3 m with Male Connector (CCP) at one end and Female Connector (CCP) at the other end as per the technical requirements.	8			
2	In-line cable assembly of length 6 m with Male Connector (CCP) at one end and Female Connector (CCP) at the other end as per the technical requirements.	8			
3	Suitable mating Flanged/ Bulkhead receptacle (FCR/ BCR) male pins with 1.5 m long pigtails, suitable for the Female Connectors mentioned in Sl.no 1 & 2.	16			
4	Suitable mating Flanged/ Bulkhead receptacle (FCR/ BCR) female pins with 1.5 m long pigtails, suitable for the male Connectors mentioned in Sl.no 1 & 2.	16			
5	Pressure rated Dummy Connectors for the Flanged/ Bulkhead receptacles mentioned in Sl.no 3.	4			
6	Pressure rated Dummy Connectors for the Flanged/ Bulkhead receptacles mentioned in Sl.no 4.	4			
7	Testing and DNV Certification	<b>Lumpsum</b>			
8	Freight and insurance charges (Warehouse to Warehouse)	<b>Lumpsum</b>			
9	Third party inspection charges for pre-shipment (Applicable for payment through LC)	<b>Lumpsum</b>			
<b>Total FOR/DAP Amount</b>					
<b>(Amount in words: _____)</b>					



## Annexure - I

### Support Letter Format in the Letter Head of the Institute/Organization

**Place:**

**Date:**

**To**

Name of the Institute/Organisation (Consortium leader)

Address Details

Subject: Design, fabrication, testing, and supply of hydraulic manipulators for a 6000 m depth rated manned submersible

Application including training and Transfer of Technology – Support Letter – reg

Reference:

Dear .....

With reference to the above mentioned referred tender from National Institute of Ocean Technology (NIOT), Ministry of Earth Sciences (MoES), Government of India, this letter confirms ..... (Name of the institute/organization) ..... desires to work on this project as a technical partner with the ..... (Consortium leader) .....

It is understood that ..... (Consortium leader) ..... will perform as the prime bidder and the technical partner as a consortium member ..... (Name of the organization) .... will work jointly with .... (Consortium leader) .....to the submit the bid for the subject of NIOT tender Design, Develop and certification of Manned Submersible personnel sphere for 6000 m and 500 m and above water depth

It is agreed that ..... (Consortium leader) .... will act as prime bidder/contractor. As such ... (Consortium leader) .....will propose, manage the overall project, coordinate with team members, and manage formal reports and communications with NIOT. Upon contract awarded to .... (Consortium leader) ..... from NIOT, we will provide full support to ensure the successful and timely execution of this project as described in the NIOT tender terms including transfer of technology. We also jointly assure NIOT that this consortium arrangement shall remain firm for the whole duration of the project if the contract is awarded. Details of consortium working arrangements including role and responsibilities of consortium members are as given in the enclosure.

Consortium jointly assures NIOT that all contractual obligation as per tender including certification, training and transfer of technology shall be honoured until completion of the project to the satisfaction of NIOT.

..... (name of the organization/institute) ..... will be involved ..... (which part of the project activity) .....

**Annexure - II**

**Format for declaration by the Bidder for Code of Integrity & conflict of interest  
(On the Letter Head of the Bidder)**

No: \_\_\_\_\_ Date \_\_\_\_\_

To,

\_\_\_\_\_

\_\_\_\_\_  
(Name & address of the Purchaser)

Sir,

With reference to your Tender No. \_\_\_\_\_ dated \_\_\_\_\_ I/We hereby declare that we shall abide by the Code of Integrity for Public Procurement as mentioned under the Clause number 55 (a) of NIT of your Tender document and have no conflict of interest.

It is certified that we are not associated, or have been associated in the past, directly or indirectly, with a firm or any of its affiliates which have been engaged by the Purchaser to provide consulting services for the preparation of the design, specifications, and other documents to be used for the procurement of the goods to be purchased under this Invitation of Bids / Tender. The details of any previous transgressions of the code of integrity with any entity in any country during the last three years or of being debarred by any other Procuring Entity are as under:

- a
- b
- c

We undertake that we shall be liable for any punitive action in case of transgression/contravention of this code.

Thanking you,

Yours sincerely,

Signature

(Name of the Authorized Signatory)

Company Seal

**ANNEXURE - III**

**MANUFACTURERS' AUTHORIZATION FORM**

The Bidder shall require the Manufacturer to fill in this Form in accordance with the instructions indicated.

This letter of authorization should be on the letterhead of the Manufacturer and should be signed by a person with the proper authority to sign documents that are binding on the Manufacturer.]

Date: [insert date (as day, month and year) of Bid Submission]

Tender No. : [insert number from Invitation For Bids]

To : [insert complete name and address of Purchaser]

**WHEREAS**

We [insert complete name of Manufacturer], who are official manufacturers of [insert type of goods manufactured], having factories at [insert full address of Manufacturer's factories], do hereby authorize [insert complete name of Bidder]to submit a bid the purpose of which is to provide the following Goods,  
manufactured by us [insert name and or brief description of the Goods],and to subsequently negotiate and sign the Contract.

We hereby extend our full guarantee and warranty in accordance with Clause 40 of the NIT, General Conditions of Contract, with respect to the Goods offered by the above firm.

Signed: [insert signature(s) of authorized representative(s) of the Manufacturer]

Name: [insert complete name(s) of authorized representative(s) of the Manufacturer]

Title: [insert title]

Duly authorized to sign this Authorization on behalf of: [insert complete name of Bidder]

Dated on \_\_\_\_\_ day of \_\_\_\_\_, \_\_\_\_\_ [insert date of signing]

\*(Not required in case the bidder itself is the manufacturer)

**ANNEXURE-IV**

**PERFORMANCE STATEMENT FORM**

Details of similar equipment / systems supplied & installed during past 3 years in India & Abroad

Name of the Firm \_\_\_\_\_

Order Placed by (full address of Purchaser)

Order Number and date:

Description and Quantity of Ordered:

Equipment Value of Order:

Date of Completion of deliver as Per Contract:

Date of actual Completion of Delivery:

Remarks Indicating reasons for late delivery, if any:

Has the Equipment Been installed/ Working Satisfactory (Attach a Certificate from The purchaser / Consignee)

Name of Contact Person along with Telephone No., FAX No. and e-mail address

Signature and Seal of the manufacturer/Bidder .....

Place :

Date :

## **ANNEXURE-V**

### **Self-Certification**

With reference to Clause No. 1.1.3 of this tender and GoI Ministry of Finance Order No.: F. No. 6/18/2019-PPD dated 23rd July, 2020 on "Restrictions under Rule 144 (xi) of the General Financial Rules (GFRs)" & OM No. F. No. 18/37/2020-PPD dated 8th February, 2021;

It is certified that

We are not a bidder of a country which shares a land border with India. OR

We are a bidder of a country which shares a land border with India, however, we are eligible to bid in any procurement whether of goods or services as we are registered with the Competent Authority as specified in Ministry of Finance (GoI) Order No. 6/18/2019 – PPD dated 23rd July 2020. Copy of valid registration is attached.

Tick as applicable

Place:

Date:

Authorised Signatory

Name:

Company Seal

## ANNEXURE-VI

### **Certificate of Local Content (To be enclosed along with Technical Bid)**

Tender No. \_\_\_\_\_

We M/s. \_\_\_\_\_ (Name of Bidder) hereby certify that we meet the minimum Local content for the Goods and services offered vide our offer/bid No. \_\_\_\_\_ dated \_\_\_\_\_ as specified below:

- Class-I Local Supplier with local content of 50% and above  
OR
- Class-II Local Supplier with local content of 20% and above but less than 50%

(Tick appropriate category of Local Supplier)

We are not claiming the services such as transportation, insurance, installation, commissioning, training, after sales service (warranty or AMC/CMC support), consultancy and custom clearance including custom duty as local value addition.

We are aware that the false declarations will be in breach of the Code of Integrity under Rule 175(1)(i)(h) of the General Financial Rules (Govt of India) for which we or our successors can be debarred for up to two years as per Rule 151 (iii) of the General Finance Rules along with such other actions as may be permissible under law.

Signed: [insert signature of person whose name and capacity are shown]

In the capacity of [insert legal capacity of person signing the Bid Submission Form]

Name: [insert complete name of person signing the Bid Submission Form]

Duly authorized to sign the bid for and on behalf of: [insert complete name of Bidder]

Dated on \_\_\_\_\_ day of \_\_\_\_\_, \_\_\_\_\_ [insert date of signing]

**ANNEXURE-VII**  
**Certificate of Price break up of Local Content**  
**(To be enclosed along with Price Bid)**

Tender No. \_\_\_\_\_

We M/s. \_\_\_\_\_ (Name of Bidder) hereby certify that we meet the minimum Local content for the Goods and services offered vide our offer/bid No. \_\_\_\_\_ dated \_\_\_\_\_ as specified below:

- Class-I Local Supplier with local content of 50% and above  
OR
- Class-II Local Supplier with local content of 20% and above but less than 50%

(Tick appropriate category of Local Supplier)

Minimum Local content is \_\_\_\_\_ % as per Price break up given below:

Component of cost Imported product Domestic value addition to product In Foreign Currency US\$ or specify In Rupees

Exchange Rate @ 1 US\$ = Rs In Rupees Location of value addition Goods

i Material

ii Equipment

iii Total Quoted Price =

(X + Y)

X =

Y =

% Local Content =  $(\frac{Y}{X+Y}) \times 100$

We are not claiming the services such as transportation, insurance, installation, commissioning, training, after sales service (warranty or AMC/CMC support), consultancy and custom clearance including custom duty as local value addition. These costs should not be included in Y above.

We are aware that the false declarations will be in breach of the Code of Integrity under Rule 175(1)(i)(h) of the General Financial Rules (Govt of India) for which we or our successors can be debarred for up to two years as per Rule 151 (iii) of the General Finance Rules along with such other actions as may be permissible under law.

Signed: [insert signature of person whose name and capacity are shown]

In the capacity of [insert legal capacity of person signing the Bid Submission Form]

Name: [insert complete name of person signing the Bid Submission Form]

Duly authorized to sign the bid for and on behalf of: [insert complete name of Bidder]

Dated on \_\_\_\_\_ day of \_\_\_\_\_, \_\_\_\_\_ [insert date of signing]

**Annexure - VIII**  
**Bid Securing Declaration Form**

Date:

E-Tender No:

E-Tender Title:

To,

NATIONAL INSTITUTE OF OCEAN TECHNOLOGY

VELACHERY TAMBARAM MAIN ROAD,

NARAYANAPURAM, CHENNAI 600 100

I/We. The undersigned, declare that:

I/We understand that, according to your conditions, bids must be supported by a bid Securing Declaration.

I/We accept that I/We may be disqualified from bidding for any contract with you for a period of one year from the date of notification if I am/ We are in a breach of any obligation under the bid conditions, because I/We

a) Have withdrawn/modified /amended impairs or derogates from the tender, my /our Bid during the period of bid validity specified in the form of Bid: or

b) Having been notified of the acceptance of our Bid by the purchaser during the period of bid validity (i) fail or reuse to execute the contract, if required, or (ii) fail or refuse to furnish the performance Security, in accordance with the Instructions to Bidders.

I/We understand this Bid Securing Declaration shall cease to be valid if I am/we are not the successful Bidder, upon the earlier of (i) the receipt of your notification of the name of the successful Bidder:

Signed: (Insert signature of person whose name and capacity are shown)

In the capacity of (insert legal capacity of person signing the Bid Security Declaration)

Name: (insert complete name of person signing the Bid Security Declaration)

Duly authorized to sign the bid for an on behalf of (insert complete name of Sole bidder/ Joint Venture /Leader of Consortium)

Dated on \_\_\_\_\_ day of \_\_\_\_\_ (insert date of signing)

Corporate Seal (where appropriate)

(Note: In case of a Joint Venture, the Bid Security Declaration must be in the name of all partners to the Joint Venture that submits the bid)

(Note: In case of a Consortium, the Bid Security Declaration to be signed by consortium lead partners that submits the bid)



## **Special Contract Conditions**

### **Technical Specifications for Power Cable Assemblies and Connectors for Thruster Controller interface in MATSYA 6000**

#### **1. Introduction**

Underwater Power cable assemblies and connectors for Thruster Controller interface will be used in MATSYA 6000 to interface the stand-alone Thruster Controllers to the Power Distribution Enclosures (PDEs) of MATSYA 6000. The Power cable assemblies and connectors are one of the most critical components in the MATSYA 6000 as they transmit the power and control signals required for functioning of the BLDC Thruster units which will be used for the propulsion of MATSYA 6000.

#### **2. Requirements of cable assemblies and connectors**

**Figure: 1** shows the Power cable interfaces between the stand-alone Thruster Controllers and the Power Distribution Enclosures of MATSYA 6000.

**3. Deliverables:** Supply of all the In-line Cable Assemblies, Flanged/ Bulkhead Receptacles, Pressure rated dummy connectors and all the other items as mentioned in Table: 2 of Special Contract Conditions (SCC) with DNV Certification/ approval for all the in-line Cable Assemblies, Flanged/ Bulkhead receptacles and pressure rated dummy Connectors.

#### **4. General Specifications**

- Each Cable assembly and Connector set shall consist of the following:
  - 1 Inline cable assembly with Cable Connector Plug (CCP) at both the ends. The CCP at one end shall be Male and the other end shall be Female.
  - 2 Suitable mating Flanged/ Bulkhead Connector Receptacles (FCR/ BCR) with pigtails for both the CCPs.
  - 3 Pressure rated dummy connectors for the FCRs/ BCRs.
  - 4 Dust caps for all the CCPs and FCRs/ BCRs.
- All the in-line cable assemblies and FCRs/ BCRs are required for Manned Submersible application having nominal diving depth (NDD) of 6000 m. The nominal pressure of components ( $P_N$ ) = 606 bar.
- The material of construction for the **Flanged/ Bulkhead receptacle body shall be Titanium alloy Grade. 5**
- All the Flanged/ Bulkhead receptacles (FCRs/ BCRs) are intended to be mounted on Dry pressure cases and shall have suitable provision for mounting on a base plate of thickness 65 mm (approximate). The BCRs (if proposed) shall have the provision of either screwing it directly to the flange or tightening it with lock nut from the pigtail end. Exact thickness of the mounting base plate will be communicated to the successful bidder/s during the placement of Purchase order/ Contract.
- All the In-line cable assemblies, Flanged/ Bulkhead receptacles and pressure rated dummies shall be provided with **proper locking arrangement** to hold the mating part tightly in mated condition. Required locking sleeves (if used) shall be included along with

the In-line Cable assemblies, Flanged/ Bulkhead Receptacles and Pressure rated Dummy Connectors. Also, suitable dust caps shall be provided for all CCPs and FCRs/ BCRs to avoid dust entry during storage.

- The **Operating temperature** rating for all the Inline cable assemblies and Connectors shall be **0 to +55°C** or better.
- All the Flanged/ Bulkhead receptacles shall be provided with 1.5 m long pigtails
- For all the in-line cable assemblies, **the connection between the CCPs is one-to-one.**

**Note:**

1. The list of in-line cable Assemblies is given as Table: 1. Detailed Technical Specification for each in-line cable assembly and receptacle is given in Table 2.
2. The maximum operating voltage for the in-line cable assemblies and receptacles is mentioned in the detailed technical specifications. **The manufacturer may select the appropriate voltage rating for the insulation materials based on the operating voltage and test requirements.**
3. The length of in-line cable assemblies may vary by  $\pm 1$  m from the values specified in Table: 2. The exact length required for each cable assembly will be communicated to the successful bidder during the placement of Purchase order/ Contact.
4. All the O-Rings required for the Connectors, FCRs/ BCRs and pressure rated dummy connectors shall be included in the supply

### **5. Testing and DNV certification/ approval**

The testing of underwater cable assemblies and flanged/ bulkhead receptacles shall be in accordance with the **DNV rules for classification of Manned Submersibles Edition July 2019**. For all hydraulic pressure tests,  **$P_N = 606$  bar**.

For all the Cable assemblies and Connectors, the testing as per DNV requirements shall be carried out in the presence of DNV surveyor and certification/ approval for usage in manned underwater vehicle application for the Nominal Diving Depth (NDD) of 6000 m shall be obtained. Gas tightness test need not be conducted.

**Note:**

1. The testing and DNV certification/ approval is the scope of the successful bidder. NIOT may depute its representatives to witness the tests. Necessary expenditure for the same will be borne by NIOT.
2. Test procedures may be devised by the successful bidder on consultation with DNV. NIOT will not provide any test procedure.
3. Testing and DNV certification/ approval charges shall be quoted separately in "lumpsum" in the BOQ and not in man hours/ daily rates. The testing charges quoted shall be inclusive of the cost of production of test pieces, fixtures etc.
4. Before the start of production of cable assemblies and connectors, the successful bidder shall obtain approval from DNV and the approved design/ fabrication/schematic drawings shall be forwarded to NIOT.
5. The successful bidder is free to conduct any other test in addition to those mentioned in DNV rules as part of their FAT within the quoted price and no additional claim will be considered.
6. All the test pieces/ samples used for **type testing** shall be discarded/ destroyed after the tests and shall not form part of the supply.

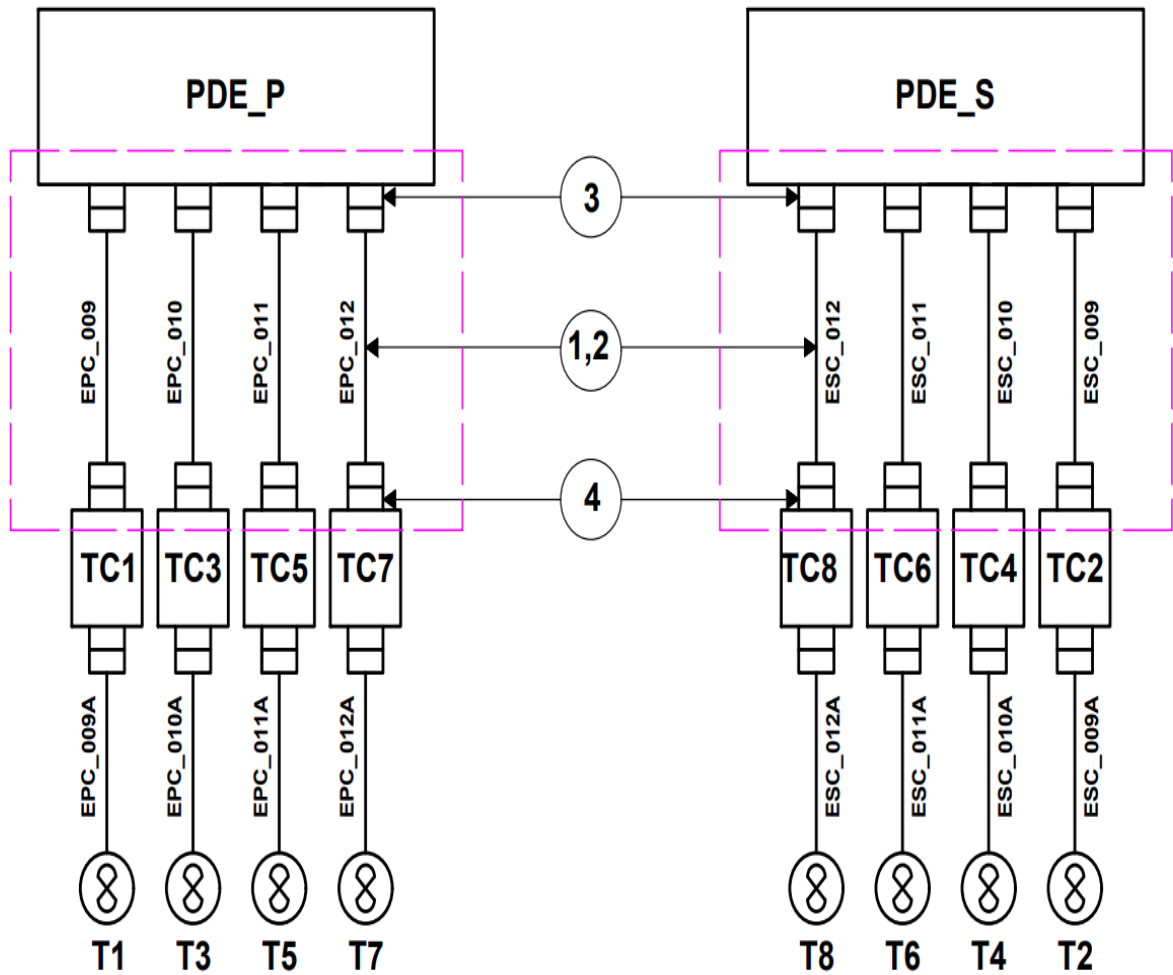

**Figure I Power Cable Assemblies and Connectors for thruster Controller interface**  
**Table: 1 - List of In-line cable assemblies required:**

S. No	Cable No.	From	To	Function
1.	EPC_009	PDE_P	TC1	Power and Control to Thruster Controller 1
2.	EPC_010	PDE_P	TC3	Power and Control to Thruster Controller 3
3.	EPC_011	PDE_P	TC5	Power and Control to Thruster Controller 5
4.	EPC_012	PDE_P	TC7	Power and Control to Thruster Controller 7
5.	ESC_009	PDE_S	TC2	Power and Control to Thruster Controller 2
6.	ESC_010	PDE_S	TC4	Power and Control to Thruster Controller 4
7.	ESC_011	PDE_S	TC6	Power and Control to Thruster Controller 6
8.	ESC_012	PDE_S	TC8	Power and Control to Thruster Controller 8

**Table: 2 - Detailed technical requirements:**

**Technical requirements (Common for S. No. 2.1 to 2.4):**

- **Current rating:**  $\geq$  (greater than or equal to) 60 A per contact/ conductor for Power pins/ lines and  $\geq$  (greater than or equal to) 5 A per contact/ conductors for Signal pins/ lines (in water).
- **Number of Contacts:**  $\geq$  (greater than or equal to) 12. Out of total contacts, 4 shall be Power contacts of  $\geq$  (greater than or equal to) 60 A rating and the balance shall be signal contacts of  $\geq$  (greater than or equal to) 5 A rating. The total permissible current through the Connector/ Cable assembly shall not be less than 120 A (in water) after considering the ampacity derating factor.
- **Operating Voltage:** 200 V DC (Maximum)
- The external diameter shall not exceed 65 mm at any part when the FCR/ BCR and CCP are mated together (exclusive of mounting Flange if FCR is proposed).
- The body of all the Connectors and Receptacles shall be of **Titanium Gr. 5**.

S. No	Description	Quantity (Nos.)
2.1	In-line cable assembly of length 3 m with Male Connector (CCP) at one end and Female Connector (CCP) at the other end as per the technical requirements mentioned above.	8.00
2.2	In-line cable assembly of length 6 m with Male Connector (CCP) at one end and Female Connector (CCP) at the other end as per the technical requirements mentioned above.	8.00
2.3	Suitable mating Flanged/ Bulkhead receptacle (FCR/ BCR), Male pins, with 1.5 m long pigtails, suitable for the Female Connector mentioned in S. No 1 & 2.	16.00
2.4	Suitable mating Flanged/ Bulkhead receptacle (FCR/ BCR), Female pins, with 1.5 m long pigtails, suitable for the Male Connector mentioned in S. No 1 & 2.	16.00
2.5	Pressure rated Dummy Connectors for the Flanged/ Bulkhead receptacle mentioned in S. No 3.	4.00
2.6	Pressure rated Dummy Connectors for the Flanged/ Bulkhead receptacle mentioned in S. No 4.	4.00

**Note:** Dust caps shall be provided for all the CCPs and FCRs/ BCRs.

## 6. Technical Specification

S. No	Description	Specification
10.1	Technical Pre-qualification Criteria	The Bidder or the corresponding OEM (in case the bidder is not the OEM for the Cable assemblies and Connectors) shall have manufactured/ supplied Underwater Cable assemblies / Connectors rated for greater than or equal to 6000 m water depth at least once during the last 10 years, year ending 31.03.2024.
10.2	Proof of fulfilment of technical pre-qualification Criteria	Proof of execution/ supply such as copies of delivery acceptance/ copy of purchase order completion certificate/ Third party inspection report for past shipments by authorized certifying agency/ testimonials from past clients etc. to be submitted. Absence/ non-submission of documentary evidence as any of the above may lead to tender being non-responsive/ invalid.
10.3	Composition of each cable assembly and connector set	<p>In-line cable assembly with Cable Connector Plug (CCP) at both the ends. The CCP at one end shall be Male and the other end shall be Female.</p> <p>Suitable mating Flanged/ Bulkhead Connector Receptacles (FCRs/ BCRs) with pigtails for both the CCPs.</p> <p>Pressure rated dummy connectors for the FCRs/ BCRs.</p> <p>Dust caps for all the CCPs and FCRs/ BCRs.</p>
10.4	Nominal pressure of components ( $P_N$ )	All the in-line cable assemblies and FCRs/ BCRs are required for Manned Submersible application having nominal diving depth (NDD) of 6000 m. The nominal pressure of components ( $P_N$ ) = 606 bar.
10.5	Material of construction for the Connector and Flanged/ Bulkhead receptacle body	<b>Titanium alloy Grade. 5</b>
10.6	Pigtail length for flanged/ bulkhead receptacles	All the flanged/ bulkhead receptacles shall be provided with 1.5 m long pigtails.

10.7	Mounting Requirement for FCRs/ BCRs	All the Flanged/ Bulkhead receptacles (FCRs/ BCRs) are intended to be mounted on Dry pressure cases and shall have suitable provision for mounting on a base plate of thickness 65 mm (approximate). The BCRs (if proposed) shall have the provision of either screwing it directly to the flange or tightening it with lock nut from the pigtail end. Exact thickness of the mounting base plate will be communicated to the successful bidder/s during the placement of Purchase order/ Contract.
10.8	Locking Arrangement	All the Inline cable assemblies, Flanged/ bulkhead receptacles and pressure rated dummies shall be provided with <b>proper locking arrangement</b> to hold the mating part tightly in mated condition.
10.9	Locking Sleeves	Required locking sleeves (if used) shall be included along with the Inline Cable assemblies, Flanged/ Bulkhead Receptacles and Pressure rated Dummy Connectors.
10.10	Dust caps	Suitable dust caps shall be provided for all CCPs and FCRs/ BCRs to avoid dust entry during storage.
10.11	Operating Temperature	0 to + 55°C or better
10.12	Operating Voltage	200 V DC (Maximum)
10.13	Length of Inline cable assemblies	Length of Inline cable assemblies may vary by $\pm 1$ m. Exact length required for each cable assembly will be communicated to the successful bidder during the placement of Purchase order/ Contract.
10.14	Requirements of O-Rings	All the O-Rings required for the Connectors, FCRs/ BCRs shall be included in the supply. One extra set of O-Ring shall be provided.
10.15	Connection between CCPs in cable assemblies	For all the cable assemblies, the connection between the CCPs is one-to-one.
10.16	Testing and DNV Certification/ approval	For all the Cable assemblies and Connectors, the testing as per DNV requirements shall be carried out in the presence of DNV surveyor and certification/ approval for usage in manned underwater vehicle application for the Nominal Diving Depth (NDD) of 6000 m shall be obtained. Gas tightness test need not be conducted.

10.17	Classification rules to be followed	The testing of underwater Cable assemblies and flanged/ bulkhead receptacles shall be in accordance with the DNV rules for classification of Manned Submersibles Edition July 2019. For all hydraulic pressure tests, $P_N = 606$ bar.
10.18	Witnessing of tests by NIOT	NIOT may depute its representative to witness the tests (Necessary expenditure will be borne by NIOT).
10.19	Scope of testing and DNV certification/ approval	The testing and DNV certification/ approval is the scope of the successful bidder. NIOT may depute its representatives to witness the tests. Necessary expenditure for the same will be borne by NIOT.
10.20	Test Procedures	Test procedures may be devised by the successful bidder on consultation with DNV. NIOT will not provide any test procedure.
10.21	Testing and DNV Certification/ approval charges	Testing and DNV certification/ approval charges shall be quoted separately in "lumpsum" in the BOQ and not in man hours/ daily rates. The testing charges quoted shall be inclusive of the cost of production of test pieces, fixtures etc.
10.22	Forwarding of DNV approved drawings	Before the start of production of cable assemblies and connectors, the successful bidder shall obtain approval from DNV and the approved design/ fabrication/ schematic drawings shall be forwarded to NIOT for reference.
10.23	Additional tests	The successful bidder is free to conduct any other test in addition to those mentioned in DNV rules as part of their FAT within the quoted price and no additional claim will be considered.
10.24	Discarding/ destroying of samples	All the test pieces/ samples used for <b>type testing</b> shall be discarded/ destroyed after the tests and shall not form part of the supply.