

 <b>राष्ट्रीय समुद्र प्रौद्योगिकी संस्थान</b> <b>NATIONAL INSTITUTE OF OCEAN TECHNOLOGY</b>	<b>संविदा आमंत्रण सूचना(नन.आ.सू.)</b> <b>NOTICE INVITING TENDER (NIT)</b>		
	<b>फ़ॉर्म</b> NIOT/S&P/NIT <b>संख्या:</b> e-procurement schedule <b>Form No.</b>		
<b>ननविदा संख्या/ Tender No.</b>		<b>NIOT/HVT/1266/2023-24</b>	
<b>कोजारी/ Tender Title</b>		Deep Ocean Simulator (DOS) – 1500 bar as per specification as per Technical specifications, Structural drawings attached in the special condition of the contract (SCC) .	
<b>ननविदा प्रणाली/Tender Mode</b>		<b>OTTB (Open Tender Two Bid)-Custom Bid (GeM)</b>	
<b>ननविदा जारी करनेकी तारीख/ Tender Issue date</b>		<b>15.11.2023</b>	
<b>Pre Bid meeting</b>		<b>23.11.2023 at 3 PM IST (Through webex)</b>	
<b>ननविदा समापन नतिथि और समय/ Tender Closing Date and Time</b>		<b>8.12.2023 at 11.00 AM</b>	
<b>ननविदा खोलनेकी नतिथि और समय/ Tender Opening Date and Time</b>		<b>8.12.2023 at 11.30 AM</b>	
<b>Submission of EMD/ ईएमडी जमा करना</b>		<b>INR. 58,00,000/-</b> in the form of DemandDraft (DD) drawn in favour of 'NIOT-OTHER RECEIPTSACCOUNT' (clause Ref 18 for details) or Bank Guarantee asper the available format. <a href="https://www.niot.res.in/index.php/vendor/login">https://www.niot.res.in/index.php/vendor/login</a> . a) Scanned copy towards EMD to be uploaded in the GeM portal b) Original EMD should be submitted through courier/speed post or in person dropped at the tender box. The original EMD should reach NIOT well before the Closing date and time of the tender.	
<b>ननविदा दस्तावेज उपलब्ध स्थान/ Tender Documents available place</b>		Tender documents can be downloaded from GeM Portal <a href="http://www.niot.res.in">and NIOTwebsite</a> www.niot.res.in till closing date and time of the Tender.	
<b>Bidding Type &amp; Bid submission/ बोलीका प्रकार &amp; ननविदा जमा करना</b>		The tender is being Two Bid system, Techno- commercial Bid and BOQ (Price Bid) should be uploaded separately and electronically through GeM Portal The price/cost should not be revealed along with the technical bid. In case, the price/cost is revealed the bid is considered as invalid and summarily rejected.	
<b>अपने प्रश्न ईमेल आईडीपर भेजें Send your queries to the email IDs</b>	<b>ननविदाके अंन्तम चरणतक/Upto Tender finalization</b>	<a href="mailto:hvt@niot.res.in">hvt@niot.res.in</a>	

राष्ट्रीय समुद्र प्रौद्योगिकी संस्थान NATIONAL INSTITUTE OF OCEAN TECHNOLOGY

वेलचेरी ताम्बरम मेन रोड VELACHERY TAMBARAM MAIN ROAD

नारायणपुरम, चेन्नै 600 100 NARAYANPURAM, CHENNAI 600 100

रा.स.प्रौ.सं. वेबसाइट/NIOT Website : <http://www.niot.res.in/tender>

## **INTRODUCTION**

National Institute of Ocean Technology (NIOT) is the technical arm of the Ministry of Earth Sciences, Government of India and is involved in developing technology for utilizing ocean resources in an eco-friendly manner.

### **Notice Inviting Tender (NIT)**

National institute of Ocean Technology invites e-bids for the **Deep Ocean Simulator (DOS) – 1500 bar as per specification** as per Technical specifications, Structural drawings attached in the special condition of the contract (SCC) .

**1. Submission of bids:** Bidders are requested to submit their Bid/quotation in two parts containing Technical proposal as Part-1 and price bid (BOQ) as Part-2 should be submitted electronically through **GeM Portal <https://gem.gov.in/>**.The responsibility to ensure timely submission of bid lies with the bidder. Bids submitted through FAX or e-mail will not be considered. Bidders shall also attach scanned copies of all the requisite documents i.e. other certificates/documents specified in the tender documents. The bids are to be submitted (electronically) as per the bidding type indicated in the front page of the NIT. The bidders are advised to register with GeM portal. Bidders are advised to submit their quotation in two Parts, **no manual tender is acceptable.**

**Part-1 should contain Techno-Commercial Bid** and duly signed blank price bid (without indicating the cost). All documents to be submitted for tender to be uploaded in the portal only. **The price/cost should not to be revealed in the technical bid, if the price/ cost is revealed, the tender will be treated as invalid.**

The bids are to be submitted as per the bidding type indicated in the front page of the NIT.

**Part-2** should contain only the price bid indicating the cost

The Part-1(Technical bid) and Part-2 (Price bid) should be uploaded separately, indicating the Tender No, Tender date, Tender due date and time. Please note that to participate in the tender. If you are a regular supplier of NIOT it is requested to register your company with portal and to procure if not owned already.

**2. NIT:** NIT shall form part of the LOI/Contract.

**3. Pre-Qualification criteria:**

**(a) Technical:-**

Supplier should be the Original Equipment Manufacturer of the complete integrated system and has experience in design, fabrication, testing, supply, installation and commissioning at site of similar hyperbaric test facility rated to minimum 500 bar internal pressure of minimum size of inner diameter 1000 mm and length 2000 mm with continuous pressure holding for 8 hrs, at least once in the last 10 years. Appropriate and comprehensive documentary proof must be submitted along with the bids. NIOT may seek additional information conclusively establish this criteria of capability & experience.

**(b)- Financial –**

(i) The average annual financial turnover of 'The bidder' during the recent three financial year ending 31.3.2023 should be at least INR 8.7 crore, for the purpose of assessing the financial strength. The documents should, duly be authenticated by a Chartered Accountant/Cost Accountant in India or equivalent in relevant countries should be submitted.

(ii) The net worth of the Bidder firm (manufacturer or principal authorized representative) should not be negative year ending 31.03.2023 and also should not have eroded by more than 30% (thirty percent) in last three years, year ending 31.03.2023 & duly be authenticated by a Chartered Accountant/Cost Accountant in India or equivalent in relevant countries should be submitted.

(iii) a) 'Doctrine of Substantial Compliance': The Pre-Qualification Bidding (PQB) and Pre-Qualification Criteria (PQC) are for short listing of sources who are competent to perform this contract to ensure best value for money from expenditure of Public Money.

This process is neither intended to bestow any entitlement upon nor to create any rights or privileges for the Bidders, by way of overly hair-splitting or viciously legalistic interpretations of these criteria, disregarding the very rationale of the PQB and PQC.

Keeping this caveat in view, interpretation by procuring entity would be based on common usage of terminologies and phrases in public procurement in accordance with the 'Doctrine of Substantial Compliance' and would be final.

b) Along with all the necessary documents/certificates required as per the tender conditions, The bidder should furnish a brief write-up, backed with adequate data, explaining his available capacity (both technical and financial), for manufacture and supply of the required goods/equipment, within the specified time of completion, after meeting all their current commitments.

c) Supporting documents submitted by the bidder must be certified as follows:

(i) All copy of supply/work order; respective completion certificate and contact details of clients; documents issued by the relevant Industries Department/National Small Industries Corporation (NSIC)/manufacturing licence; annual report, etc., in support of experience, past performance and capacity/capability should be authenticated by the by the person authorized to sign the tender on behalf of the bidder. Original Documents must be submitted for inspection, if so demanded.

(ii) All financial standing data should be certified by certified accountants, for example, Chartered Accountants/Cost Accountants or equivalent in relevant countries; and Indian bidder or Indian counterparts of foreign bidders should furnish their Permanent Account Number (PAN).

**INSTRUCTION TO BIDDERS:**

4. **Security:** Any information /material/document uploaded along with this tender or after award of contract should not be disclosed or copied without written permission from NIOT.

5. **Contacting NIOT:** No correspondence / discussion / visits whatsoever will be entertained on the subject unless specifically called by this office after opening the tender for clarifications in writing. Any violation of this will render the quotation invalid and the firm is liable

to be removed from our approved vendor list. However, if bidder requires any clarification on the bid, the query may be mailed to the mail ID **hvt@niot.res.in**

6. **Tender Opening:** All the tenderers can participate in the e-tender opening with proper authorization letter from the respective Company.

7. **Default in Performance:** If any bidder is not successfully discharging their contract obligations against the awarded contract on them by NIOT within the agreed time limit, (OR) if there is any deficiency in performing such obligations, NIOT reserves the right to suspend such bidder from their participation in future tenders of NIOT for a period of one year. Even after revoking the suspension period the bidder's performance still continues to be the same without any improvement, NIOT reserves right to BAN such bidder permanently from participation in all the tenders of NIOT and organizations of MOES.

8. **Goods:** Goods should be supplied only after receipt of duly signed Contract from NIOT

9. **LOI Acceptance:** The successful bidder should accept the LOI within 15 days from the date of receipt of the LOI, failing which it shall be presumed that the bidder is not interested, and the EMD submitted will be forfeited.

10. **Signing of Contract:** On successful evaluation and declaration of the Successful bidder, initially a Letter of Intent will be issued by NIOT. The successful bidder should submit his acceptance of LOI within 15 days along with the deliverables as sought in the LOI and copy of power of attorney along with the Board resolution copy authorizing the signatory to sign the contract with NIOT. If the Director of the company is signing the contract the copy of the MOA to be submitted, upon receipt of acceptance of LOI and other relevant documents mentioned, a contract shall be signed between NIOT and the successful bidder.

11. **Change of Name after award:** Request / intimations with regard to change of name of the contracting company or constitution of the contractor after the tender opening or award of contract shall not be allowed as a matter of right. The bidders/ contractors are required to submit all relevant documents with regard to change of name or /and change of constitution and the circumstances leading to such change beforehand. It shall be the discretion of NIOT to proceed with the contract after such changes and in case, NIOT decides to proceed with the contract, it may require the contractor to execute further agreements with regard to execution/ implementation of the contract.

12. **One Bid per Bidder:** A firm shall submit only one bid either individually or as a partner of a joint venture. A firm that submits either individually or as a member of a joint venture, if a bidder submit more than one bid will result in rejection of all the bids.

#### **BIDDING CONDITION**

13. **Deadline for Submission of Bids:** Bids must be received by NIOT at the GeM portal specified in the Invitation for Bids cover page on or before the due date/ extended due date thereof.

**14. Due date Extension, Corrigendum to NIT:** Any corrigendum including due date extension for NIT, Pre-bid minutes of meeting will be notified in GeM portal and NIOT website. Hence bidders are requested to watch NIOT website/ GeM portal for such due date extension and corrigendum, if any.

**15. In case of the unscheduled holiday in Chennai** being declared on the prescribed closing / opening day of the tender, the next working day will be treated as the scheduled prescribed day of closing/opening day of the tender.

**16. Unsolicited correspondences:** NIOT will not entertain any unsolicited correspondence or queries on the status of offer against this tender.

**17. Non-Receipt of Tender:** NIOT will not be responsible for the non-receipt of the tender due to any network problem.

**18. Submission of tender by a tenderer** implies that he has read the Notice Inviting Tender and has made himself aware of the scope and specifications of the work to be done; conditions and rates at which stores, tools and plant etc. will be issued to him by NIOT; local conditions and other factors bearing on the execution of the works.

**19. EMD/Bid security:** The EMD/Bid security is mandatory as indicated in the cover page and should be submitted along with the technical bid for the value indicated in the front page of this tender document. The EMD/Bid security is mandatory requirement as indicated in the cover page and should be submitted along with the technical bid for the value indicated in the front page of this tender document. Bids without EMD will be summarily rejected.

The EMD /bid security may be accepted in the following form

- (1) Insurance Surety Bonds,
- (2) Account Payee Demand Draft (drawn in favour of " NIOT other Receipt Account", Chennai in INR or in equivalent foreign currency),
- (3) Fixed Deposit Receipt,
- (4) Banker's Cheque or Bank Guarantee from any of the Commercial Banks. (BankGuarantee as per prescribed format available in the NIOT web site at the link

<https://www.niot.res.in/index.php/vendor/login>

- (5) Online payment in an acceptable form.

If the EMD (scanned copy of the instrument of EMD) is not submitted along with Techno-commercial (Part-I). The bid will be summarily rejected. The original EMD should be submitted (or) reach NIOT on or before closing date the time of the tender.

**MSME Clause:**

"Micro and Small Enterprises (MSEs) as defined in MSE Procurement Policy issued by Department of Micro, Small and Medium Enterprises (MSME)" are exempt from submission of EMD (Bid security). Bidders claiming exemption of EMD under this rule (170of GFR) are however required to

submit a signed bid securing declaration (format to be enclosed) along with the relevant and valid exemption certificate issue by the appropriate authorities. accepting that if they withdraw or modify their Bids during the period of validity, or if they are awarded the contract and they fail to sign the contract, or to submit a performance security before the deadline defined in the request for bids document, they will be suspended for the period of one year from being eligible to submit Bids for tenders with NIOT and all the departments under MoES." The bid declaration format to be attached in the Annexure.

**MSME Conditions:**

- (a) The MSE's bidder who claim EMD request should submit the relevant document towards investment on equipment and machinery. As per NIT clause no 60 make in India as per the DPIIT order under Annexure 9, under MSE.
- (b) the MSE's bidder to note and ensure that nature of service and goods/items manufactured mentioned in MSE's certificate matches with the nature of the service and goods/item to be supplied as per tender.
- (c) Retail & Whole sale Traders : Any bidder who are retailer / Traders claim EMD / Bid security exemption shall refer Ministry OM 5/2(2)/2021-E/P&G/Policy dtd 02.07.2021 & 5/2(1)2020/E-P&G/Policy dtd 01.12.2020.

The MSME is classified as mentioned below; (Ref Ministry of MSME Notification dated 26.06.2020)

- (i) **Micro Enterprises:** Where the investment in plant and machinery or equipment does not exceed 1 crore rupees and turnover does not exceed 5 crore rupees,
- (ii) **Small Enterprises:** Where the investment in plant and machinery or equipment does not exceed 10 crore rupees and turnover does not exceed 50 crore rupees,
- (iii) **Medium Enterprises:** Where the investment in plant and machinery or equipment does not exceed 50 crore rupees and turnover does not exceed 250 crore rupees

**20. Conditions for EMD / Bid Security:** EMD shall be returned / discharged to unsuccessful bidders within 15 days after the expiration of the period of bid validity or placement of LOI whichever is later. EMD may be forfeited:

- a. If a bidder withdraws, modifies for provided unsolicited offer voluntarily revising the price in whatsoever aspect its bid during the period of bid validity specified by the bidder on the bid form or
- b. In case of a successful bidder, fails to furnish order acceptance within 15 days of the LOI and / or fails to furnish Performance Security.

EMD for a successful bidder shall be adjusted against performance security payable if submitted in DD / refunded if / performance security is submitted.

**21. Bid Validity:** Bids shall remain valid and open for acceptance for a minimum period of **90 days** from the date of opening of Un-priced Techno-commercial bids when fully compliant tender is submitted by the bidder without any requirement for NIOT to seek additional documents towards evaluation of pre-qualification and/or in ensuring conformance to the specification/requirements of the tender. In the event of any delay in evaluation attributable to the vendor, bidder shall extend

the tender by such a time taken by them in addition to above minimum tender validity period. A bid valid for shorter validity period will be considered as a conditional tender and treated as invalid tender.

22. **Bid validity extension:** While NIOT will finalize the tender within the bid validity sought as per this NIT, due to circumstances beyond the control of NIOT, prior to expiry of the original bid validity period, **NIOT may request the bidder for a specified extension of the bid validity without modifying RFP or Price.** The request and the responses thereto shall be made in writing. A bidder agreeing to the request will extend the validity of his bid correspondingly. When bid validity is extended EMD BG also deemed to have been extended automatically for which necessary action would be taken by the bidder to submit the extended BG well before the expiry of the current validity.

23. **Conditional offers:** Conditional offer will not be accepted.

24. **Signing of bids:** Each page of the tender document shall be digitally signed by the bidder and should be uploaded along with all other documents.

25. **The broad configuration:** Specification of the proposed purchase /work are given. Bidders are required to keep their proposal strictly as per the specification prescribed.

26. **Acceptance of bids:** NIOT may accept or reject any/all tenders including the lowest tender without assigning any reasons whatsoever. NIOT also reserves its right to accept any tender in part or parts only with such conditions as it may prescribe. NIOT is not bound to accept the lowest tender. NIOT expects full technical compliance and expects full scope of integrated supply as per tender specification and do not accept partial tenders.

27. **The compliance sheet** with reference to the specifications should be furnished against each parameter while submitting the quotation, which is absolutely necessary. THE TENDERER SHALL SUBMIT TECHNICAL & COMMERCIAL COMPLIANCE SHEETS and BOQ (Price bid) separately ALONG WITH THEIR OFFER. TENDERS WITHOUT COMPLIANCE SHEETS WILL NOT BE EVALUATED. The Price bid should be unconditional.

28. **Canvassing:** Exerting pressure and/or offering inducement in any form by the bidder or by any other person on behalf of the bidder shall disqualify the bid and lead to its rejection.

29. **Award:** NIOT shall place the LOI for each of the title.

30. **Bid or modification** to bids received after closing date and time shall not be considered. Such modified bid together with original bid will be summarily rejected. Modification to the bid after opening the bid will not be considered unless specifically requested for by NIOT and only in case if there is an absolute necessity to revise the technical specifications after opening of bid.

31. **Unrealistic bids** with either cost which is impossible to achieve or for bidders who show that they are completely inexperienced or have completely inappropriate equipment will be rejected.

## **TERMS AND CONDITIONS GOVERNING THE CONTRACT**

**32. Currency of bids:**

**Local firms inside Chennai:** Quotations should indicate the cost with free delivery upto NIOT. If quote is for Ex-Godown rate delivery charges should be indicated separately and explicitly. The word „Extra“ shall be avoided.

**Firms outside Chennai:** Quotations should be F.O.R, NIOT, Chennai. If F.O.R.consignment freight charges by passenger train / Road transport must be indicated. If EX- Godown, packing and forwarding and freight charges must be indicated separately. Goods should be supplied carriage paid and insured for Contractor godown to consignee warehouse Chennai.

**33. Price:** The price shall include but not limited to

- a) Costs of goods/ services covered in this Contract.
- b) Taxes and duties
- c) Transportation and packing cost (Sea/Air worthy packing of internationally acceptable practices withstand transit and Transshipments by sea / air / road / rail)
- d) Cost of handling, documentation, freight, insurance from Contractor's warehouse up to NIOT warehouse, installation and commissioning of the equipment when part of Contractual obligation.

**34. GST:** GST will be as per HSN code as applicable.

**Deductibles:**

**a) Deduction of Indian Income Tax Deduction at Source for the Indian bidders:** TDS will be deducted as applicable for service portion at prevailing rates. Valid Permanent Account Number (PAN) is mandatory.

**b) GST-TDS:**

GST-TDS is deductible on supply of goods or Service in respect of Intra – State supplies at the rate of 2% (CGST @1% and SGST @ 1%) and also in case of Inter-State supplies @ the rate of 2% from the payment made or credited to the supplier of taxable Service.

**35. Guaranteed time of delivery – specific performance of contract:** The time of delivery including testing and handing over in satisfactory condition is the essence of the contract and the item should be supplied as per specification and scope of supply as per SCC. In the event of part supply, NIOT shall withhold the entire payment until the whole of the supply as per the contract is delivered. The entire item to be supplied & commissioned within **1 5 months** from the date of signing of the contract.

**36. Extension of delivery period:** If the completion of systems / components is delayed for reasons of force majeure such as acts of God, Acts of Public enemy, acts of Government, fires, floods, epidemics, quarantine restrictions, illegal strikes and freight embargoes, the Contractor shall within 3 days from the date of such occurrence, give notice to NIOT in writing of his claim for extension of delivery period. NIOT on receipt of such notice may agree to extend the Contract delivery date as may be reasonable but without prejudice to other terms and conditions of the contract. Unless the extended delivery period is agreed by NIOT in writing, contractor cannot claim the extension of delivery time as a matter of right. NIOT shall have the right to either cancel/extend the order validity/ levy LD as appropriate.



**37. Delay in Completion/Liquidated Damage (LD):** If the Contractor shall fail to deliver the systems / components within the time specified in the Contract, NIOT shall recover from the Contractor as liquidated damages a sum of 0.5% of the Contract price of the undelivered systems /components for each calendar weeks of delay. The total liquidated damages shall not exceed 10% (ten percent) of the Contract value of the unit or units so delayed. Systems / components will be deemed to have been delivered only when all essential components parts are also delivered. If any essential components are not delivered in time, the entire system / components will be considered as delayed until such time the undelivered parts/components/systems are delivered.

**38. Insurance:** The Goods supplied under the Contract shall be fully insured against loss or damage incidental to manufacture or acquisition, transportation, storage and delivery in the manner specified in the NIT. If any such damage occurred, the goods shall be replaced within in the Contract price immediately without waiting for the insurance claim. The cost of insurance shall be in the scope of the bidder.

**39. Risk Purchase:** If the Contractor fails to deliver the stores or any instalment thereof within the period fixed for such delivery or at any time repudiates the Contract before expiry of such period, NIOT is entitled to cancel the Contract and source remaining items from any parties the stores not delivered at the risk and cost of the defaulting Contractor. No payment claimed for any part supplies made.

**40. Risk and Insurance:**

The Bidder/Contractor shall take out and keep in force the following adequate insurance to cover all risks including but not limited to third party risk coverage and shall submit to NIOT copy of policy:

During the development of the system, testing, trials and all transportation including transit up-to receipt of the Product / material at NIOT and acceptance after final phase of testing including during field operations.

The Bidder/Contractor shall take out and keep in force, adequate insurance in respect of their own as well as hired equipments (to the extent of their insurable interest) tools, materials, marine spreads, vessels, barges, crafts ships and operational facilities used during the entire period of their engagement in connection with the Contractor to the insurable value of such constructional plant, equipment and other things. NIOT shall have no liability whatsoever in this regard. NIOT shall not consider any claim whatsoever, hence Bidder/Contractor shall assess all possible risks and take adequate all risk insurance cover including transit insurance. General terms and conditions for tender submission& evaluation

NIOT reserves right to reject any or all of the bids received in response to this invitation to tender without assigning any reasons whatsoever.

Bidder shall note that NIOT will not entertain any correspondence or queries on the status of the offers received against this Tender Invitation.

Canvassing in any form by any bidder or by any other agency acting on behalf of the partner after submission of bid may disqualify the said partner. NIOT's decision in this regard shall be final and binding on the partner.

**41. (a)Warranty:**

The warranty should be valid for 12 months from Deep Ocean Simulator (DOS) system installation,

commissioning & acceptance at NIOT, Chennai.

The Contract warrants that the Goods supplied under this Contract are new, unused, of the most recent or current models and those they incorporate all recent improvements in design and materials unless provided otherwise in the Contract. The contractor further warrants that all Goods supplied under this Contract shall have no defect arising from design, materials or workmanship or from any act or omission of the contractor that may develop under normal use of the supplied Goods in the conditions prevailing in the country of final destination. This warranty should be minimum for the period for **12 months after acceptance of item at NIOT.**

The warranty certificate should be furnished in the prescribed format available on the NIOT web site at the link

<https://www.niot.res.in/index.php/vendor/login> in the Contractor letterhead. If the Manufacturer standard warranty is more than 12 months the same shall be extended to NIOT without any restriction whatsoever. NIOT shall promptly notify the Contractor in writing of any claims arising under this warranty. Upon receipt of such notice, the Contractor shall, with all reasonable speed, repair or replace the defective Goods or parts thereof, without cost to NIOT other than, where applicable, the cost of inland delivery of the repaired or replaced Goods or parts from ex- works or ex-factory or ex-showroom to the final destination. If the Contractor, having been notified, fails to remedy the defect(s) within a reasonable period, NIOT may proceed to take such remedial action as may be necessary, at the Contractor's risk and expense and without prejudice to any other rights which NIOT may have against the Contractor under the Contract. Also, such failure shall lead to suspension of vendor from participation as deemed fit by NIOT.

### **(b) Defect Liability.**

Any defect shrinkage, settlement or any other faults for components etc., which may appear against the set quality or performance characteristics within the Defects Liability period (DLP), within 12 months (DLP and O&M shall commence immediately after acceptance of the materials after due performance trials as per SCC after the virtual completion of performance evaluation (one month) of the equipments. Arising in the opinion of the NIOT from materials or workmanship not in accordance with the contract, shall on demand which shall be made within the defects liability period, in writing by the NIOT and within such reasonable time as shall be stated therein specifying the work, materials or articles complained of notwithstanding that the same may have been passed or/and certified, paid form be amended and made good by the supplier.

Supplier at his own proper charge cost and in case of default the NIOT may employ and pay other person or persons to amend and make good such defects, shrinkage settlements or other faults and all damages, losses and expenses consequent thereon or incidental there to shall be made good and borne by the supplier and such damages, losses and expenses shall upon the NIOT, certificate in writing, be recoverable from the supplier by the NIOT or may be deducted by the NIOT from any moneys due or that may become due to the supplier. NIOT may in lieu of such amending and making good by the contractor deduct from any moneys equivalent to the cost of amending and making good such work and in the event of the amount retained being insufficient, recover the balance from the supplier, together with any expenses NIOT may have incurred in connection therewith. any defective work have been done or materials supplied by the supplier or their associates employed in /NIOT the contractor supplier shall be liable to make the same good in the

same manner as if such work or materials had been subject to the provisions. Any delay in rectifying the defects within a maximum time of one month shall result in automatic extension of DLP within contract price to the extent of delay for rectification.

### **( C ) Comprehensive Extended Warranty: For 3 years**

Comprehensive Extended warranty shall commence from the date of expiry of 12 month of standard warranty.

Pro-rata Payment for the extended warranty shall be released for every completion half yearly period only after expiry of such comprehensive extended warranty period after completion of **standard 12 months** warranty period.

Comprehensive extended warranty for three years including deputing of technical personnel during the warranty period on as required basis to address issues as applicable. The warranty shall be comprehensive, i.e. the necessary repairs/service at NIOT shall be undertaken including supply of the required spares consumption , etc within Comprehensive extended warranty quoted price.

**42. Discounts:** Bidders are advised not to indicate separate discounts. Discounts, if any, should be duly considered and nett rate should be quoted in the BOQ/Price Bid.

**43. Performance Security:**

The successful bidders should deposit 5% of the contract value as Performance Security within two weeks from the date of issue of LOI. The Performance security may be accepted in the following form

- (1) Insurance Surety Bonds,
- (2) Account Payee Demand Draft (drawn in favour of" The Director N.I.O.T", Chennai in INR or

in equivalent foreign currency).

- (3) Fixed Deposit Receipt from any Commercial Bank.
- (4) Bank Guarantee from any of the Commercial Banks.
- (5) Online payment in an acceptable form.

Performance security shall be forfeited in the event of breach of Contract by the Contract in terms of the Contract. If Performance Security is not paid within the specified time, NIOT reserves its right to cancel the order/ LOI and forfeit the EMD /Bid security.

Bank Guarantee shall be as per prescribed format issued by a Commercial bank and valid for 60 days beyond the scheduled delivery / completion period as per LOI / Contract. This format can be downloaded from the link <https://www.niot.res.in/index.php/vendor/login>. Performance security shall be forfeited in the event of breach of Contract by the Contract or in terms of the Contract.

**44. Performance Guarantee/ Warranty Bank Guarantee:** As per the MoFS guidelines 10% of the item value to be retained towards warranty to ensure the performance of the equipment's/systems to avoid any defect due to material/ workmanship or any omission on the part of the contract to rectify the same during the warranty period. If performance bank guarantee for 10% of the item value is submitted and valid till completion of the warranty period and acceptance then 100% payment will be released. The warranty Bank Guarantee will be discharged after completion of the standard warranty period.

45. **Payment:**

<b>Stage .no</b>	<b>Mile stone deliverables</b>	<b>Amount (or )% payable</b>	<b>Bank Guarantee to equivalent value in INR</b>	<b>Time Line for stage</b>
1	On receipt & acceptance of design document - Design calculation and Finite Element Analysis (FEA) report, calculation of fatigue life prediction of facility, comprehensive drawings of all parts and assembly drawing (2D and 3D), facility layout drawing (plan and elevation), hydraulic circuit drawing, pneumatic circuit drawing, pressure line drawing, electric circuit drawing & control circuit drawing against submission of equivalent value of BG.	10 % of the Item value	Against submission of 110% bank guarantee for this stage payment	T + 2 months
2	On receipt & acceptance of raw material procurement and testing & Certificate Reports (material chemical and mechanical properties, forging heat number, heat treatment, NDT (X-ray/Ultrasound), manufacturing/fabrication process etc.)	20 % of Item value	Against submission of 110% bank guarantee for this stage payment	T + 6 months
3	On receipt & acceptance FAT and Third party inspection reports.	25 % of Item value	Against submission of 110% bank guarantee for this stage payment	T + 9 months
4	on receipt & acceptance of DOS system to NIOT	20 % of Item value	Against submission of 110% bank guarantee for this stage payment	T + 12 months
5	on receipt & acceptance and, successful installation & commission, training of Deep Ocean Simulator (DOS) at NIOT	15 % of Item value + Other charges	Release of all BGs obtained at sl no 1-4 above. Also release of balance payment	T + 15 months

		quoted in the BOQ(2-9)	if any against such deliverables	
6	On completion of 12 month warranty	10 % of Item value	Ref Clause no 44.	Signing of the contract + 27 months

**Note:** For all advance stage payments above up to receipt of items at NIOT covering BG for 100 % amount paid will be required to be provided by the contractor and it should valid up to delivery and acceptance of the system and successful installation and commission, training of Deep Ocean Simulator (DOS) at NIOT. **(T - Date of signing the contract)**

**Mode of Payment :** All payment will be released within 30 days after submission of deliverables as per NIT clause (45) and certified by the NIOT authorized officials.

Comprehensive extended warranty payment shall be paid on pro rata basis. Half yearly basis.

**46. Force Majeure:** For purposes of this Clause, "Force Majeure" means an event beyond the control of the Contractor and not involving the Contractor's fault or negligence and not foreseeable. Such events may include, but are not limited to, acts of NIOT either in its sovereign or Contractual capacity, wars or revolutions, fires, floods, epidemics, quarantine restrictions and freight embargoes.

If a Force Majeure situation arises, the Contractor shall promptly notify NIOT in writing of such conditions and the cause thereof. Unless otherwise directed by NIOT in writing, the Contractor shall continue to perform its obligations under the Contract as far as is reasonably practical, and shall seek all reasonable alternative means for performance not prevented by the Force Majeure event.

**47. Mediation/Arbitration / Disputes:**

In the event of any dispute any time during the entire duration of contract, both the parties shall try to resolve through mutual discussion to resolve such disputes. In case the same is not resolved, parties will submit for mediation to IEM under the Integrity Pact and as per extant instructions of Govt. of India for resolution. No party shall rush to any court of law without completion of mediation and arbitration as contemplated. In the event of any dispute, difference, interpretation or application relating to this agreement arises, the same shall be settled amicably by the parties .

In the event of any dispute, difference, interpretation or application relating to this agreement arises; the same shall be settled amicably by the parties. In case the dispute or differences could not be settled amicably, the same shall be referred for adjudication through arbitration by an arbitrator to be appointed by the Director, NIOT with mutual consent.

The Indian Arbitration shall be concluded in accordance with the provisions of Arbitration &

Conciliation Act, 1996 or any statutory modifications or re-enactment thereof and the rules made there under and for the time being in force shall apply to the arbitration proceedings. Venue of such arbitration shall be at Chennai in India. The language of arbitration proceedings shall be English. The Arbitrator shall make reasoned award (the "award"), which shall be final and binding on the parties. The cost of the arbitration shall be shared equally by the parties to the contract. However, expenses incurred by each party in connection with the preparation, presentation etc., shall be borne by each party.

**48. SUBMISSION OF TECHNICAL DOCUMENT:** Specifications are basic essence of the product. The broad configuration / specification of the proposed purchase are given in NIT the Special Conditions of the contract (SCC). It must be ensured that the offers are strictly as per our specifications as mentioned in the Annexure - I & Drawings of NIT(SCC). At the same time, it must also be kept in mind that merely copying our specifications in their quotation shall not make firms eligible for consideration. Technically unsuitable offers and offers not conforming to tender schedule shall be rejected.

a. The bidder is required to provide their comments item-by-item on the compliance sheet provided in the Annexure - I & Drawings of NIT (SCC). Wherever the specified parameter is required within a range, the calculated/ estimated value as per the vendor's design is to be provided in the "Remarks" column. Deviations/exceptions, if any, from the specifications to be recorded in the "Remarks" column.

b. Offer must contain all relevant technical details. Relevant preliminary drawings (if any) pertaining to the quoted designs, duly signed by the authorized official shall be sent along with the quotation. Wherever mentioned, documentary evidence has to be enclosed in the quotation. Any erasures / over writing shall be counter signed by the person who is signing the bid. Any interlineations, erasures or overwriting shall be valid only if the person or persons signing the bid sign them.

c. NIOT will not provide any test procedures. All relevant required tests as mentioned in the technical specification to conduct within the quote price.

**49. ASSIGNMENT AND SUBCONTRACTING** The Contractor shall not assign the Contract or any part thereof, or any benefit or interest therein or hereunder, nor assume a fresh partner or partners nor dissolve the partnership at present subsisting between them in reference to this Contract without a formal written request and approval by NIOT. Also, the Contract shall not assign the Contract or any part thereof, or any benefit or interest therein or hereunder, nor assume a fresh partner or partners nor dissolve the partnership at present subsisting between them in reference to this Contract without a formal written request and approval by NIOT. Also, partnerships or third-party vendors during Tender should not be altered without a written approval.

**50. Eligible Bidders**

Bidders should not be associated, or have been associated in the past, directly or indirectly, with a firm or any of its affiliates which have been engaged by the Purchaser to provide consulting services for the preparation of the design, specifications, and other documents to be used for the

procurement of the goods to be purchased under this Invitation of Bids.

The bidders who have been temporarily suspended or removed from the list of registered suppliers by the purchaser or banned from Ministry/country wide procurement shall be ineligible for participation in the bidding process.

### **51. Confidentiality**

51.1. Information relating to the examination, evaluation, comparison, and post qualification of bids, and recommendation of purchase order award, shall not be disclosed to bidders or any other persons not officially concerned with such process until Award of the Purchase order. However, decisions taken during process of tender evaluation shall be hosted on e-wizard portal.

52.2. Any effort by a Bidder to influence the Purchaser in the examination, evaluation, comparison, and post qualification of the bids or purchase order award decisions may result in the rejection of its Bid.

### **53. Cost of Bidding**

The Bidder shall bear all costs associated with the preparation and submission of its bid, and "the Purchaser", will in no case be responsible or liable for these costs, regardless of the conduct or outcome of the bidding process.

#### **53.1 Code of Integrity for Public Procurement**

53.2. The purchaser requires that the bidders, suppliers and purchase orders observe the highest standard of ethics during the procurement and execution of such purchase orders. In pursuit of this policy, the following are defined:

Sr. No. Term Meaning

#### **(a) Corrupt practice**

The offering, giving, receiving, or soliciting, directly or indirectly, of anything of value to influence the action of a public official in the procurement process or in purchase order execution.

#### **(b) Fraudulent practice**

A misrepresentation or omission of facts in order to influence a procurement process or the execution of a purchase order.

#### **(c) Collusive practice**

Means a scheme or arrangement between two or more bidders, with or without the knowledge of the purchaser, designed to establish bid prices at artificial, non-competitive levels.

#### **(d) Coercive practice**

Means harming or threatening to harm, directly or indirectly, persons or their property to influence their participation in the procurement process or affect the execution of a purchase order.

#### **(e) Anticompetitive practice**

Any collusion, bid rigging or anti-competitive arrangement, or any other practice coming under the purview of the Competition Act, 2002, between two or more bidders, with or without the

knowledge of the purchaser, that may impair the transparency, fairness and the progress of the procurement process or to establish bid prices at artificial, non-competitive levels

**(f) Conflict of interest**

participation by a bidding firm or any of its affiliates that are either involved in the consultancy purchase order to which this procurement is linked; or if they are part of more than one bid in the procurement; or if the bidding firm or their personnel have relationships or financial or business transactions with any official of purchaser who are directly or indirectly related to tender or execution process of purchase order; or improper use of information obtained by the (prospective) bidder from the purchaser with an intent to gain unfair advantage in the procurement process or for personal gain

**(g) Obstructive practice**

materially impede the purchaser's investigation into allegations of one or more of the above mentioned prohibited practices either by deliberately destroying, falsifying, altering; or by concealing of evidence material to the investigation; or by making false statements to investigators and/or by threatening, harassing or intimidating any party to prevent it from disclosing its knowledge of matters relevant to the investigation or from pursuing the investigation; or by impeding the purchaser's Entity's rights of audit or access to information

53.3. The Purchaser will reject a proposal for award if it determines that the Bidder recommended for award has, directly or through an agent, engaged in corrupt, fraudulent, collusive or coercive practices in competing for the Purchase order in question.

53.4. The bidders/suppliers should sign a declaration about abiding by the Code of Integrity for Public Procurement and submit it in the form as per Annexure-II along with bid documents. In case of any transgression of this code, the bidder is not only liable to be removed from the list of registered suppliers, but it would be liable for other punitive actions such as cancellation of purchase orders, banning and blacklisting or action by Competition Commission of India, and so on.

53.5. Obligations for Proactive disclosures

a) The Purchaser as well as bidders, suppliers, purchase orders and consultants, are obliged under Code of Integrity for Public Procurement to sue-moto proactively declare any conflicts of interest (coming under the definition mentioned above – pre-existing or as and as soon as these arise at any stage) in any procurement process or execution of purchase order. Failure to do so would amount to violation of this code of integrity.

b) The bidder must declare, whether asked or not in a bid document, any previous transgressions of such a code of integrity with any entity in any country during the last three years or of being debarred by any other Procuring Entity. Failure to do so would amount to violation of this code of integrity.

c) To encourage voluntary disclosures, such declarations would not mean automatic disqualification for the bidder making such declarations. The declared conflict of interest would be evaluated and mitigation steps, if possible, taken by the purchaser.

53.6. Punitive Provisions

Without prejudice to and in addition to the rights of the Purchaser to other penal provisions as per



the bid documents or purchase order, if the Purchaser comes to a conclusion that a (prospective) bidder/supplier, directly or through an agent, has violated this code of integrity in competing for the purchase order or in executing a purchase order, the purchaser may take appropriate measures including one or more of the following:

a) If his bids are under consideration in any procurement:

- i. Forfeiture or encashment of bid security;
- ii. Calling off of any pre-purchase order negotiations; and
- iii. Rejection and exclusion of the bidder from the procurement process.

b) If a purchase order has already been awarded

- i. Cancellation of the relevant purchase order and recovery of compensation for loss incurred by the Purchaser;
- ii. Forfeiture or encashment of any other security or bond relating to the procurement;
- iii. Recovery of payments including advance payments, if any, made by the purchaser along with interest thereon at the prevailing rate.

c) Provisions in addition to above:

- i. Removal from the list of registered suppliers and banning/debarment of the bidder from participation in future procurements of the purchaser for a period not less than one year;
- ii. In case of anti-competitive practices, information for further processing may be filed under a signature of the Joint Secretary level officer, with the Competition Commission of India;
- iii. Initiation of suitable disciplinary or criminal proceedings against any individual or staff found responsible.

#### **54. Amendment to Bidding Documents**

In order to allow prospective bidders reasonable time to take the amendment into account while formulating their bids, the Purchaser, at its discretion, may extend the due date for the submission of bids and host the changes on the GEM portal through a corrigendum

#### **55. Documents Establishing Goods' Goods' Eligibility and Conformity to Bidding Documents**

55.1. To establish the goods' eligibility, the documentary evidence of the goods and services eligibility shall consist of a statement on the country of origin of the goods and services offered which shall be confirmed by a certificate of origin at the time of shipment.

55.2. To establish the conformity of the goods and services to the specifications and schedule of requirements of the bidding document, the documentary evidence of conformity of the goods and services to the bidding documents may be in the form of literature, drawings and data, and shall consist of :

- a) A detailed description of the essential technical and performance characteristics of the goods;
- b) A list giving full particulars, including available sources and current prices, of spare parts, special tools, etc., necessary for the proper and continuing functioning of the goods during the warranty period following commencement of the use of the goods by the Purchaser in the Price-bid ; and

c) An item-by-item commentary on the Purchaser's Technical Specifications demonstrating substantial responsiveness of the goods and services to those specifications or a statement of deviations and exceptions to the provisions of the Technical Specifications.

55.3. For purposes of the commentary to be furnished pursuant to above, the Bidder shall note that standards for workmanship, material and equipment, designated by the Purchaser in its Technical Specifications are intended to be descriptive only and not restrictive. The Bidder may substitute these in its bid, provided that it demonstrates to the Purchaser's satisfaction that the substitutions ensure substantial equivalence to those designated in the Technical Specifications.

## **56. Contacting the Purchaser**

a) No Bidder shall contact the Purchaser on any matter relating to its bid, from the time of the bid opening to the time the Contract is awarded.

b) Any effort by a Bidder to influence the Purchaser in its decisions on bid evaluation, bid comparison or Contract award may result in rejection of the Bidder's bid.

### **Post qualification**

c) In the absence of pre-qualification, the Purchaser will determine to its satisfaction whether the bidder that is selected as having submitted the lowest evaluated responsive bid is qualified to perform the Contract satisfactorily, in accordance with the criteria listed in the SCC of the NIT.

d) The determination will take into account the Eligibility & Qualification criteria listed in the SCC of the NIT and it will be based upon an examination of the documentary evidence of the bidder's qualifications submitted by the bidder, as well as such other information as the Purchaser deems necessary and appropriate.

e) An affirmative determination will be a prerequisite for award of the Contract to the Bidder. A

negative determination will result in rejection of the Bidder's bid.

## **57. Bidder's right to question rejection**

A Bidder shall have the right to be heard in case he feels that a proper procurement process is not being followed and/or his tender has been rejected wrongly. Only a directly affected bidder can represent in this regard as under:

57.1 Only a bidder who has participated in the concerned procurement process i.e. pre-qualification, bidder registration or bidding, as the case may be, can make such representation.

57.2 In case pre-qualification bid has been evaluated before the bidding of Technical bids, an application for review in relation to the technical bid may be filed only by a bidder who has qualified in prequalification bid.

57.3 In case technical bid has been evaluated before the opening of the financial bid, an application for review in relation to the financial bid may be filed only by a bidder whose technical bid is found to be acceptable.

57.4 In case a Bidder feels aggrieved by the decision of the purchaser, he may then send his representation in writing to the Purchaser's address as indicated in special conditions of Contract (SCC) within 05 working days from the date of communication of the purchaser intimating the rejection for reconsideration of the decision by the purchaser.

57.5 Following decisions of the purchaser in accordance with the provision of internal guidelines shall not be subject to review:

- (a) Determination of the need for procurement;
- (b) Selection of the mode of procurement or bidding system;
- (c) Choice of selection procedure;
- (d) Provisions limiting participation of bidders in the procurement process;
- (e) The decision to enter into negotiations with the L1 bidder;
- (f) Cancellation of the procurement process except where it is intended to subsequently re-tender the same requirements;
- (g) Issues related to ambiguity in purchase order terms may not be taken up after a purchase order has been signed, all such issues should be highlighted before consummation of the purchase order by the vendor/contractor; and
- (h) Complaints against specifications except under the premise that they are either vague or too specific so as to limit competition may be permissible.

**58. Termination of contract by NIOT:**

a) The contract shall become effective from the date of signing of contract and the contract shall automatically get terminated after successful completion of all contractual obligation and warranty obligation as per the terms of the contract.

b)

- (i) Termination of the contract due to breach of contract by the contractor
- (ii) Termination of contract due to default,
- (iii) Termination of the contract due to insolvency,
- (iv) Termination of the contract for convenience.

If the termination of the contract happens due to the above factors, [(i), (ii) &(iv)] initially the written notice will be issued within 30 days to settle the issue on mutually agreed terms with mutual consent.

Else, the matter will be referred to the Mediators (IEMs) for their advise /settlement. If the settlement is not fruitful the parties can proceed for arbitration as per the clause No.47. of NIT During this process the contract will be in live and continue to be live till the termination notice is issued. If the contract is terminated due to the any factors above, except (iii) depending on the merit of the case, the contractor shall be suitably compensated and mutual agreed terms for terminating the contract shall be arrived with the consent of IEMs.

**59. INDEMNITIES:** The Purchase order hereby agrees to indemnify and hold harmless NIOT and its Director, officers and employees, from and against any and all suits, losses, liabilities, damages, claims, settlements, costs and expenses, including reasonable attorneys' fees, based on arising, directly or indirectly, from:

- i. breach of this Agreement by the Purchase order
- ii. Not performing the Scope of Work or any other obligation under this Agreement or Tender in accordance with the provisions and schedules of this Agreement or the Tender

- iii. Violation or contravention of any Legislation on the part of the Purchase order
- iv. Any negligence or wilful misconduct of Purchase order, which violates any provision of this Agreement
- v. Infringement of any intellectual property belonging to any third party by the Purchase order
- vi. Any breach of an agreement or understanding between Purchase order and any and all Third Parties due to which a liability arises on NIOT.
- vii. Any claim that any representations or warranties contained herein are not true or Any breach thereof
- viii. Any loss or damage caused by the Purchase order to NIOT, its personnel or property
- ix. Any loss or damage caused by the Purchase order to any and all Third Parties for which a claim against NIOT has arisen
- x. Breach, expiry, cancellation, revocation or invalidity of any and all licenses, permits, authorizations and registrations which the Purchase order is required to obtain, keep valid and comply with under any Legislation in order to perform its obligations hereunder
- xi. Any obligation of the Purchase order performed by NIOT under this Agreement or under any Legislation.

## **60. Preference to Make in India**

**Make in India-Price Preference-MSME** Price preference to Local suppliers as per Make in India procurement policy of Govt of India shall refer the order DPIIT Order No. P-45021/2/2017- PP (BE-II) dated 16th September 2020 issued by Ministry of Commerce (Govt. of India)

Definitions of terms applicable to Make in India procurement policy of Govt of India:-

- a) 'Local content ' means the amount of value added in India which shall be the total value of the item procured (excluding net domestic indirect taxes) minus the value of imported content in the item (including all customs duties) as a proportion of the total value, in percent.
- b) 'Class-I Local supplier' means a supplier provider whose product offered for procurement meets the local content of 50% and above.
- c) 'Class-II Local supplier' means a supplier provider whose product offered for procurement meets the local content of 20% and above but less than 50%.
- d) 'Non-Local supplier' means a supplier provider whose product offered for procurement meets the local content of less than 20%.
- e) 'L1' means the lowest tender or lowest bid or the lowest quotation received in this tender, bidding process or other procurement solicitation as adjudged in the evaluation process as per the tender or other procurement solicitation.
- f) 'Margin of purchase preference ' means the maximum extent to which the price quoted by a

local supplier may be above the L1 for the purpose of purchase preference.

### **I. Purchase preference: -**

- a) Among all qualified bids, the lowest bid will be termed as L1. If L1 is from a Class-I local supplier, the contract for full quantity will be awarded to L1.
- b) If L1 bid is not from a Class-I local supplier, 50% of the order quantity shall be awarded to L1. Thereafter, the lowest bidder among the Class-I local suppliers, will be invited to match the L1 price for the remaining 50% quantity subject to the local supplier's quoted price falling within

the margin of purchase preference, and contract for that quantity shall be awarded to such Class-I local supplier subject to matching the L1 price. In case such lowest eligible Class-I local supplier fails to match the L1 price or accepts less than the offered quantity, the next higher Class-I local supplier within the margin of purchase preference shall be invited to match the L1 price for remaining quantity and so on, and contract shall be awarded accordingly. In case some quantity is still left uncovered on local suppliers, then such balance quantity may also be ordered on the L1 bidder.

c) In the procurements of goods or works, which are covered by para 3(b) or reference order and which are not divisible in nature, and in procurement of services where the bid is evaluated on price alone, the 'Class-I local supplier' shall get purchase preference over 'Class-II local supplier' as well as 'Non-local supplier', as per following procedure:

(i) Among all qualified bids, the lowest bid will be termed as L1. If L1 is from a Class-I local supplier, the contract will be awarded to L1.

(ii) If L1 is not from a Class-I local supplier, the lowest bidder among the Class-I local suppliers, will be invited to match the L1 price subject to local supplier's quoted price falling within the margin of purchase preference, and the contract shall be awarded to such Class-I local supplier subject to matching the L1 price.

(iii) In case such lowest eligible Class-I local supplier fails to match the L1 price, the Class-I local supplier with the next higher bid within the margin of purchase preference shall be invited to match the L1 price and so on and contract shall be awarded accordingly. In case none of the Class-I local suppliers within the margin of purchase preference matches the L1 price, then the contract may be awarded to the L1 bidder.

(iv) Only Class-II Local suppliers are not eligible to get price preference in any procurement undertaken by procuring entities.

## **II. Applicability in tenders where contract is to be awarded to multiple bidders: -**

In tenders where contract is awarded to multiple bidder's subject to matching of L 1 rates or otherwise, the 'Class-I local supplier' shall get purchase preference over 'Class-II local supplier' as well as 'Non-local supplier', as per following procedure:

a) In case there is sufficient local capacity and competition for the item to be procured, as notified by the nodal Ministry, only Class I local suppliers shall be eligible to bid. As such, the multiple suppliers, who would be awarded the contract, should be all and only 'Class I Local suppliers'.

b) In other cases, 'Class II local suppliers' and 'Non-local suppliers' may also participate in the bidding process along with 'Class I Local suppliers' as per provisions of this Order. c) If 'Class I Local suppliers' qualify for award of contract for at least 50% of the tendered quantity in any tender, the contract may be awarded to all the qualified bidders as per award criteria stipulated in the bid documents. However, in case 'Class I Local suppliers' do not qualify for award of contract for at least 50% of the tendered quantity, purchase preference should be given to the 'Class I local supplier' over 'Class II local suppliers'/ 'Non local suppliers' provided that their quoted rate falls within 20% margin of purchase preference of the highest quoted bidder considered for award of contract so as to ensure that the 'Class I Local suppliers' taken in totality are considered for award of contract for at least 50% of the tendered quantity.

d) First purchase preference has to be given to the lowest quoting 'Class-I local supplier', whose quoted rates fall within 20% margin of purchase preference, subject to its meeting the prescribed criteria for award of contract as also the constraint of maximum quantity that can be sourced from any single supplier. If the lowest quoting 'Class-I local supplier', does not qualify for purchase preference because of aforesaid constraints or does not accept the offered quantity, an

opportunity may be given to next higher 'Class-I local supplier', falling within 20% margin of purchase preference, and so on.

e) To avoid any ambiguity during bid evaluation process, the procuring entities may stipulate its own tender specific criteria for award of contract amongst different bidders including the procedure for purchase preference to 'Class-I local supplier' within the broad policy guidelines stipulated in sub-paras above

### **III. Minimum local content:-**

The 'local content' requirement to categorize a supplier as 'Class-I local supplier' is minimum 50%. For 'Class-II local supplier', the 'local content' requirement is minimum 20%. Nodal Ministry/ Department may prescribe only a higher percentage of minimum local content requirement to categorize a supplier as 'Class-I local supplier'! 'Class-II local supplier'. For the items, for which Nodal Ministry! Department has not prescribed higher minimum local content notification under the Order, it shall be 50% and 20% for 'Class-I local supplier'! 'Class-II local supplier' respectively.

### **IV. Verification of Local content:-**

a. The 'Class-I local supplier'! 'Class-II local supplier' at the time of tender, bidding or solicitation shall be required to indicate percentage of local content and provide self-certification that the item offered meets the local content requirement for 'Class-I local supplier'! 'Class-II local supplier', as the case may be. They shall also give details of the location(s) at which the local value addition is made.

b. In cases of procurement for a value in excess of Rs . 10 crores, the 'Class-I local supplier'! 'Class-II local supplier' shall be required to provide a certificate from the statutory auditor or cost auditor of the company (in the case of companies) or from a practicing cost accountant or practicing chartered accountant (in respect of suppliers other than companies) giving the percentage of local content.

c. False declarations will be in breach of the Code of Integrity under Rule 175(1)(i)(h) of the General Financial Rules for which a bidder or its successors can be debarred for up to two years as per Rule 151 (iii) of the General Financial Rules along with such other actions as may be permissible under law.

### **V. Manufacture under license/ technology collaboration agreements with phased indigenization:-**

While notifying the minimum local content, Nodal Ministries may make special provisions for exempting suppliers from meeting the stipulated local content if the product is being manufactured in India under a license from a foreign manufacturer who holds intellectual property rights and where there is a technology collaboration agreement / transfer of technology agreement for indigenous manufacture of a product developed abroad with clear phasing of increase in local content.

### **VI. Classification of MSE'S:-**

i) Micro Enterprises: Where the investment in plant and machinery or equipment does not exceed 1 crore rupees and turnover does not exceed 5 crore rupees,

(ii) Small Enterprises: Where the investment in plant and machinery or equipment does not exceed 10 crore rupees and turnover does not exceed 50 crore rupees,

(iii) Medium Enterprises: Where the investment in plant and machinery or equipment does not exceed 50 crore rupees and turnover does not exceed 250 crore rupees

(iv) Retail & Whole sale traders: Any bidder who are retailer/ Traders claim EMD/ Bid security exemption shall refer Ministry OM 5/2(2)/2021-E/P&G/Policy dtd 02.07.2021 &

5/2(1)2020/E- P&G/Policy dtd 01.12.2020.

**VII. Price Preference to MSEs: -**

- a) Among the qualified bids, the lowest bid will be termed as L1, If L1 is class 1 local supplier the contract will be awarded to L1.
- b) In tender, participating Micro and Small Enterprises quoting price within price band of L1 + 15% shall also be allowed to supply a portion of requirement by bringing down their price to L1 price in a situation where L1 price is from someone other than a Micro and Small Enterprise and such Micro and Small Enterprise shall be allowed to supply up to 25 percent of the total tendered value, The 25(twenty five)% quantity is to be distributed proportionally among these bidders, in case there are more than one MSME's within such price band.
- c) In case the tendered quantity of goods cannot be split/ divided MSE quoted price within the band L1+15% may be awarded for full complete supply of total tendered value to MSE.
- d) MSEs participating in the tender must submit valid & authorized copy of certificate of registration with any one of the above agencies. In case of bidders submitting DIC registration certificate shall attach original notarized copy of the DIC certificate.
- e) The MSE's Bidder to note and ensure that nature of services and goods/items manufactured mentioned in MSE's certificate matches with the nature of the services and goods /items to be supplied as per Tender.
- f) The registration certificate issued from any one of the above agencies must be valid as on Bid closing date of the tender. Bidder shall ensure validity of registration certificate in case bid closing date is extended.
- g) The MSEs who have applied for registration or renewal of registration with any of the above agencies / bodies, but have not obtained the valid certificate as on close date of the tender, are not eligible for EMD exemption / preference.
- h) Where any aggregator has been appointed by the Ministry of MSE, themselves quote on behalf of some MSE units, such offers will be considered as offer from MSE units and all such facilities would be extended to these aggregators also.

**61. Pre Bid meeting:** Pre bid meeting shall be held **23.11.2023 at 3 PM IST (through webex)** through video conference to clarify queries from all potential bidders. Potential bidders are advised to send their queries sufficiently in advance by email to [hvt@niot.res.in](mailto:hvt@niot.res.in). The meeting link will be uploaded as a corrigendum. A Corrigendum will be issued based on pre-bid meeting clarifications and shall form part of the NIT.

**62. Authorisation:** The bidder is qualified only when he is the original manufacturer or established dealer with original manufacturer's authorization letter to quote, sell and service the products offered as per the prescribed format in our web site along with agency agreement.

**63. Integrity pact**

NIOT have to adopt an Integrity pact (IP) to ensure transparency, equity and competitiveness in major Public procurement activities. The integrity pact envisages an agreement between the prospective bidders/vendors with NIOT committing the persons/officials of both the parties with the aim not to exercise any corrupt influence on any aspect of the contract. The bidders shall agree to enter into such an integrity pact with NIOT as per forms available in the website [www.niot.res.in](http://www.niot.res.in) (Attached as annexure)

#### **64. Intellectual Property Rights (IPR)**

NIOT shall have a right of use to all deliverables provided by CONTRACTOR for the ordinary purpose of this contract and make similar systems in the future. As long as the payment for services according to the milestone payment plan plus any additional costs if applicable does not take place, all rights in the CONTRACTOR deliverables remain with CONTRACTOR.

#### **65. Joint Venture, Consortium or Association**

If the Supplier is in a joint venture, consortium, or association, all of the parties shall be jointly and severally liable to the Purchaser for the fulfilment of the provisions of the Contract and shall designate one party to act as a leader with authority to bind the joint venture, consortium, or association. The composition or the constitution of the joint venture, consortium, or association shall not be altered without the prior consent of the Purchaser.

Amalgamation/Acquisition etc:

In the event the Manufacturer/Supplier proposes for amalgamation, acquisition or sale its business to any firm during the Contract period, the Buyer/Successor of the Principal Company are liable for execution of the Contract and also fulfilment of Contractual obligations i.e. supply, installation, commissioning, warranty, maintenance/replacement of spares accessories etc. You may confirm this condition while submitting the bid.

#### **66. Buy Back:**

The successful bidder has to take the old item on as is where is basis condition. The transportation of the old item is the responsibility of the successful bidder. On placement of the LOI/Signing the contract, the old item has to be lifted within one month of the date of signing of the contract.



**Commercial Terms Compliance sheet (To be filled by the bidder)**

Sl.No	Particulars	Yes	No	Page Ref
1.	Whether Taxes and duties are shown separately in the quote. (Registration numbers for claiming the same to be strictly indicated)			
2.	Whether EMD for <b>Rs.58,00,000/-</b> is enclosed along with the Technical bid			
3.	Whether accepted to submit the LOI acceptance within 15 days from the date of LOI?			
4	Whether submission of Performance Security 5% is acceptable?			
5.	Whether Quote is valid for <b>90 days</b> from the due date of tender or time specified in the tender document whichever is later?			
6.	Whether <b>payment terms</b> of the tender is complied with?			
7.	Whether price is <b>FOR</b> NIOT, Chennai			
8	Whether submission of <b>warranty</b> certificate in the prescribed format is acceptable?			
9	Whether the <b>delivery period</b> is acceptable as per tender? (i.e. 15 month from the date of LOI)			
10	Whether list of deliverables attached and comply as per tender?			
11	Whether liquidated damage clause is acceptable in case of delayed supply?			
12	Whether the tender is fully complying with tender specification/Adjustment if no, list out deviations very clearly along with the appropriate reason for the deviation?			
13	Whether item-wise price is quoted as per price bid and quoted price is realistic?			
14	Whether copy of duly signed (all pages) tender document NIT and Annexure (I to XI) are uploaded along with the quotation.			
15	Whether the pre-contract integrity pact is signed by the authorized signatory and uploaded?			
16	Whether the Buy back clause is acceptable?			



**SPECIAL CONDITIONS OF THE CONTRACT (SCC)****Specification of Deep Ocean Simulator - 1500 bar (DOS-1500)****1. Scope of work**

System configuration, supply, installation, commissioning, and operational training of a Deep Ocean Simulator (DOS) as per tender specification and terms and conditions for NIOT, Chennai.

Buyback of the existing hyperbaric test facility units (900 bar) from NIOT, Chennai, (India).

**2. Description of DOS - 1500**

A fixed installation deep ocean simulator, termed as DOS - 1500 capable of sustained internal pressure of 1500 bar at 1 to 5 °C internal temperature, for testing subsea components in live condition.

**3. Technical Specification of DOS - 1500 & Technical compliance sheet (to be filled by the bidder)**

Ser	Description	Details	Complied / Not complied
<b>System configuration</b>			
3.1	Configuration	Capable of installation within existing facility and high pressure pit - Refer Annexure 1	
<b>Size of vessel</b>			
3.2	Working inner diameter and inner length	Diameter 1.25 m Length 3.0 m	
<b>Major parts</b>			
3.3	Body & lid	<ul style="list-style-type: none"> <li>Top mounting configuration of test units. Closure cover to be screw or similar type. But not flange bolted type.</li> <li>Feed through ports/connector facility shall be provided at least at the top cover/lid.</li> </ul>	
3.4	Interfaces	As per the manufacturer' design on concurrence of NIOT	
<b>High pressure sealing</b>			
3.5	Seals	Suitable high pressure axial and radial seals as per design for rated pressure	
<b>Maximum working pressure and temperature</b>			
3.6	Pressure type	Internal, hydrostatic pressure using water as working fluid	

3.7	Working pressure	1500 bar for sustained duration of minimum 10 hr	
3.8	Working fluid temperature range	Minimum: 1 to 5 °C for simulating deep sea at a normal ambient temperature at Chennai (India), at as high as 40 °C	
3.9	Measurements	<ul style="list-style-type: none"> <li>• Operating pressure and temperature in chamber to be recorded and visually displayed on the control panel, including raising and lowering of pressures</li> <li>• Water level sensor in the reservoir to be recorded and visually displayed on the control panel in addition to the view port on the reservoir</li> <li>• The facility should have analogue and digital display of parameters for pressure, temperature etc.</li> </ul>	
<b>Cooling system</b>			
3.10	System	As required to provide the required temperature of working fluid. The working fluid should be able to reach required low temperature within 1 hour of commencement and sustained over the duration of the tests.	
3.11	Vessel cooling arrangement	Suitable cooling arrangement on the vessel, closure and supporting system shall be provided to maintain the required temperature.	
3.12	Mounting	Compact/Modular - Externally installed Air cooled system	
<b>Vessel mounting details</b>			
3.13	Position	Vertical installation in the existing setup. Pit of opening size of Length 4.0, width 4.0 m with depth of 4.5 m	
3.14	Work load fixture/tooling	Suitable work load fixture/tooling for mounting the vessel and handling the test components inside the vessel to be provided	
3.15	Vessel mounting	Below ground level at existing facility	
3.16	Mounting stand	Suitable mounting stand shall be	

		provide by manufacturer	
<b>Material of construction</b>			
3.17	Material	As per the manufacturer	
<b>Working medium</b>			
3.18	Medium	Potable water with additives (overall transparent medium) as indicated by the supplier	
3.19	Reservoir	Suitable reservoir should be supplied by manufacturer	
3.20	Additives/hydraulic oils	Required additives and oils used should be standard and normally available material and not proprietary or exclusive.	
<b>Feed through port/connector facility</b>			
3.21	Type	Flange with suitable O-Ring and fasteners	
3.22	Quantity	<ul style="list-style-type: none"> <li>• 12 nos. (Feed through ports/connectors of type thread – 6 nos. &amp; flange – 6 nos. should be provided on the top cover)</li> <li>• Detailed specification of the ports for bulk head connectors will be provided during fabrication</li> </ul>	
<b>Hoisting mechanism</b>			
3.23	Type	Automatic and manual gantry/actuator type hoisting mechanism for engaging/disengaging, locking/unlocking of closures to be designed, realized and integrated with overall system	
<b>Control unit</b>			
3.24	Type	Manual/automated testing through PLC/Advanced system to be integrated with the facility for operation for both pressure testing and hoist movement	
3.25	Logger	<ul style="list-style-type: none"> <li>• Continues logging of measured data should be programmed with the control unit (data transfer through UPS device)</li> <li>• Real time measurements (pressure vs time,</li> </ul>	

		<p>temperature vs time, water level on reservoir vs time etc.) shall be displayed on the control panel in graphical format</p> <ul style="list-style-type: none"> <li>• Pressure test data should be available in readable format</li> <li>• Capable of generating online/offline reports</li> </ul>	
<b>Safety device</b>			
3.26	Safety device	Manufacturer to provide required safety devices, alarm, warning systems as per intended standard during operation and maintenance of the integrated system	
3.27	Air venting	Suitable venting arrangement should be provided for releasing of air inside the vessel during filling and draining operation	
3.28	Safety grating/mesh	Safety grating/mesh shall be provided by manufacturer	
<b>Pressurizing and decompression unit</b>			
3.29	Pressurizing and decompression	<ul style="list-style-type: none"> <li>• <b>Pressurizing:</b> Facility to raise or decrease the internal test pressure in range of at least 1 to 60 bar/minute. Anything better is also acceptable. Pressure built up rate/pressure ramp should be adjustable through control panel</li> <li>• <b>Decompression:</b> Pressure decompression rate should be adjustable by manual or through control panel at 1 to 60 bar/minute or better.</li> <li>• <b>Low pressure pump:</b> Suitable low pressure pump shall be provided by manufacturer for filling/draining of HTF cylinder</li> <li>• <b>High pressure pump:</b> Suitable high pressure pump shall be provided by manufacturer for pressurizing of high pressure</li> </ul>	

		medium	
3.30	Mode of operation	Manual/auto/pressure step up & down modes of pressurizing and decompression operations	
<b>Test Component:</b>			
3.31	Mass of test component	Maximum 5000 kg in air	
<b>Pressure Testing</b>			
3.32	Design pressure	As per ASME or equivalent standard (to be specified in bid)	
3.33	Test pressure	As per ASME or equivalent standard (to be specified in bid) and not less than 1.4 times working pressure (1500 bar)	
<b>Third party certification</b>			
3.34	Approval agencies	ASME, TUV, DNV, LLOYDS or any other internationally approved IACS inspection agencies or equivalent agencies for design, assembly, integration, testing and acceptance of internal high pressure vessels	
<b>Inspection and Acceptance Test</b>			
3.35	Factor Acceptance Tests (FATs)	Factory acceptance test for final assembly, integration at system & component level for specified functional and performance to be witnessed and certified by the third party agencies indicated above. NIOT officials may also attend the tests.	
3.36	Acceptance Tests	Post completion integration and assembly at NIOT, facility to be comprehensively demonstration for performance to be undertaken.	

#### 4. Terms and Conditions

##### 4.1 Buyback

Buyback of the existing test facility from NIOT, Chennai, India (Hyperbaric Test Facility, HTF - Diameter 1.0 m x 3.0 m length/900 bar) at a cost. The buyback as discount in the quoted price cost should be indicated in the price bid in the format.

##### 4.2 Deliverables

Supplier shall supply, deliver, integrate and commission the complete system at NIOT, Chennai as per the technical specification with spares (Ref ser 4.5).

### **4.3 Civil work**

Civil construction requirements viz. building, crane (EOT crane), pneumatic line, water supply and power will be undertaken by NIOT on design, safety, foundation/pit requirements and manufacturing details being provided by the Supplier, within two months of LOI/Purchase Order/Contract whichever is earlier.

### **4.4 Training**

The bidder/supplier/manufacture shall train at least five (05) NIOT Scientists/Engineers on the following during Factor Acceptance Tests (FATs) at supplier works and during installation and commissioning of the Deep Ocean Simulator at NIOT.

- a) Operation and maintenance of DOS, including trouble shooting.
- b) Electrical/Controls/hydraulic system.
- c) Safety and Emergency system.
- d) Safety of equipment/human during pressure testing and qualification.
- e) Repair/Servicing.

### **4.5 Spare parts**

- a) Recommended maintenance tools and spares/consumables/repair kit as required for the DOS - 1500 system to be supplied, for at least three (03) years of trouble free operation.
- b) The required items to be assessed and provided by the bidder.
- c) The list of items to be supplied as spares shall be provided along with technical bid.

### **4.6 Package and Transportation**

The whole system has to be packed and transported to NIOT, Chennai. Third party inspection is required during packing and for safe transport of item from supplier premises. Required insurance shall be taken by the supplier.

### **4.7 Documents**

The bidder/supplier/manufacture should provide two set of documents in soft and hard copy along with the supply and not limited to the list below for both system.

- a) Design document bringing out the details and material specification of the chamber, lids, attachments, actuators, sensors and seals.
- b) Design calculation and Finite Element Analysis (FEA) report
- c) Calculation of fatigue life prediction of facility.
- d) Comprehensive drawings of all parts and assembly drawing (2D and 3D) that are supplied.
- e) Facility layout drawing (plan and elevation), hydraulic circuit drawing, pneumatic circuit drawing, pressure line drawing, electric circuit drawing & control circuit drawing.
- f) Stress-strain measurement values at critical points during pressure testing (working, design, design pressure and test pressure as per standard).



- g) Test & Certificate Reports (material chemical and mechanical properties, forging heat number, heat treatment, NDT (X-ray/Ultrasound), manufacturing/fabrication process etc.).
- h) Third party inspection reports.
- i) Operations manual including alarms and trouble-shooting.
- j) Maintenance & repair manual.
- k) Bill of materials and spare parts catalogue.
- l) Controller software copy.

#### **4.8 Maintenance support:**

Life time free support to be provided in upkeep, update and repair of the control and operation software through remote access, as and when requisitioned.

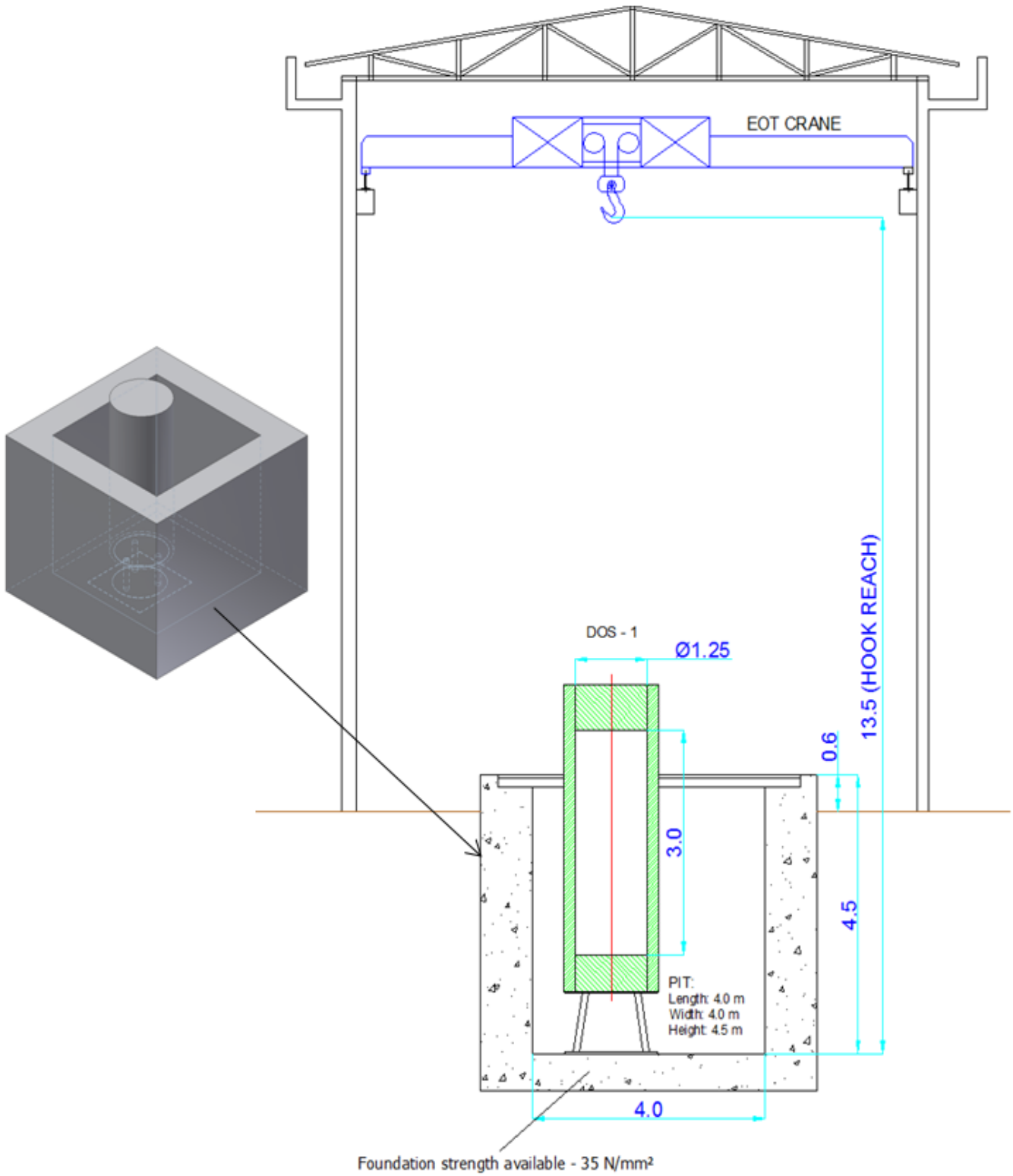

Existing installation Pit (All dimensions are in mm)

**Annexure -II**

Bid Securing Declaration Form

Date:

E-Tender No:

E-

Tender

Title: To.

NATIONAL INSTITUTE OF OCEAN  
TECHNOLOGYVELACHERY TAMBARAM  
MAIN ROAD, NARAYANAPURAM,  
CHENNAI 600 100

I/We. The undersigned, declare that:

I/We understand that, according to your conditions, bids must be supported by a bid Securing Declaration.

I/We accept that I/We may be disqualified from bidding for any contract with you for a period of one year from the date of notification if I am/ We are in a breach of any obligation under the bid conditions, because I/We

- a) Have withdrawn/modified /amended impairs or derogates from the tender, my /our Bid during the period of bid validity specified in the form of Bid: or
- b) Having been notified of the acceptance of our Bid by the purchaser during the period of bid validity (i) fail or reuse to execute the contract, if required, or (ii) fail or refuse to furnish the performance Security, in accordance with the Instructions to Bidders.

I/We understand this Bid Securing Declaration shall cease to be valid if I am/we are not the successful Bidder, upon the earlier of (i) the receipt of your notification of the name of the successful

Bidder: Signed: (Insert signature of person whose name and capacity are shown)

In the capacity of (insert legal capacity of person signing the Bid Security Declaration) Name: (insert complete name of person signing the Bid Security Declaration)

Duly authorized to sign the bid for an on behalf of (insert complete name of Sole bidder/ Joint Venture /Leader of Consortium)

Dated on \_\_\_\_\_ day of \_\_\_\_\_ (insert date of signing) Corporate Seal (where appropriate)

(Note: In case of a Joint Venture, the Bid Security Declaration must be in the name of all partners to the Joint Venture that submits the bid)

(Note: In case of a Consortium, the Bid Security Declaration to be signed by consortium lead partners that submits the bid)

**ANNEXURE - III**

**MANUFACTURERS' AUTHORIZATION FORM**

The Bidder shall require the Manufacturer to fill in this Form in accordance with the instructions indicated. This letter of authorization should be on the letterhead of the Manufacturer and should be signed by a person with the proper authority to sign documents that are binding on the Manufacturer.]

Date: [insert date (as day, month and year) of Bid Submission]

Tender No. : [insert number from Invitation For Bids]

To : [insert complete name and address of Purchaser]

**WHEREAS**

We [insert complete name of Manufacturer], who are official manufacturers of [insert type of goods manufactured], having factories at [insert full address of Manufacturer's factories] , do hereby authorize [insert complete name of Bidder] to submit a bid the purpose of which is to provide the following Goods, manufactured by us [insert name and or brief description of the Goods], and to subsequently negotiate and sign the Contract.

We hereby extend our full guarantee and warranty in accordance with Clause 40 of the NIT, General Conditions of Contract, with respect to the Goods offered by the above firm.

Signed: [insert signature(s) of authorized representative(s) of the Manufacturer] Name:

[insert complete name(s) of authorized representative(s) of the Manufacturer] Title:

[insert title]

Duly authorized to sign this Authorization on behalf of: [insert complete name of Bidder]

Dated on \_\_\_\_\_ day of \_\_\_\_\_, \_\_\_\_\_ [insert date of signing]

\*(Not required in case the bidder itself is the manufacturer)

**ANNEXURE-IV**

**PERFORMANCE STATEMENT FORM**

Details of similar equipment / systems supplied & installed during past 3 years in India & Abroad

Name of the Firm \_\_\_\_\_

Order Placed by (full address of Purchaser)

Order Number and date:

Description and Quantity of Ordered:

Equipment Value of Order:

Date of Completion of deliver as Per Contract:

Date of actual Completion of Delivery:

Remarks Indicating reasons for late delivery, if any:

Has the Equipment Been installed/ Working Satisfactory (Attach a Certificate from The purchaser / Consignee)

Name of Contact Person along with Telephone No., FAX No. and e-mail address

Signature and Seal of the manufacturer/Bidder .....

Place :

Date :

**Annexure – V**

Format for declaration by the Bidder for Code of Integrity & conflict of interest  
(On the Letter Head of the Bidder)

No: \_\_\_\_\_ Date \_\_\_\_\_

To,

(Name & address of the Purchaser)

Sir,

With reference to your Tender No. \_\_\_\_\_ dated \_\_\_\_\_ I/We hereby declare that we shall abide by the Code of Integrity for Public Procurement as mentioned under the Clause number 55 (a) of NIT of your Tender document and have no conflict of interest.

It is certified that we are not associated, or have been associated in the past, directly or indirectly, with a firm or any of its affiliates which have been engaged by the Purchaser to provide consulting services for the preparation of the design, specifications, and other documents to be used for the procurement of the goods to be purchased under this Invitation of Bids / Tender. The details of any previous transgressions of the code of integrity with any entity in any country during the last three years or of being debarred by any other Procuring Entity are as under:

a

b

c

We undertake that we shall be liable for any punitive action in case of transgression/ contravention of this code.

Thanking you,

Yours sincerely,

Signature

(Name of the Authorized Signatory)

Company Seal

**ANNEXURE-VI**

**Certificate of Local Content  
(To be enclosed along with Technical Bid)**

Tender No. \_\_\_\_\_

We M/s. \_\_\_\_\_ (Name of Bidder) hereby certify that we meet the minimum Local content for the Goods and services offered vide our offer/bid No.

\_\_\_\_\_ dated \_\_\_\_\_ as specified below:

- Class-I Local Supplier with local content of 50% and above
- OR
- Class-II Local Supplier with local content of 20% and above but less than 50%

**(Tick appropriate category of Local Supplier)**

We are not claiming the services such as transportation, insurance, installation, commissioning, training, after sales service (warranty or AMC/CMC support), consultancy and custom clearance including custom duty as local value addition.

We are aware that the false declarations will be in breach of the Code of Integrity under Rule 175(1)(i)(h) of the General Financial Rules (Govt of India) for which we or our successors can be debarred for up to two years as per Rule 151 (iii) of the General Finance Rules along with such other actions as may be permissible under law.

Signed: [insert signature of person whose name and capacity are shown]

In the capacity of [insert legal capacity of person signing the Bid Submission Form]

Name: [insert complete name of person signing the Bid Submission Form]

Duly authorized to sign the bid for and on behalf of: [insert complete name of Bidder]

Dated on \_\_\_\_\_ day of \_\_\_\_\_, \_\_\_\_\_ [insert date of signing]

**ANNEXURE-VII**  
**Certificate of Price break up of Local Content (To be enclosed along with Price Bid)**

Tender No. \_\_\_\_\_

We M/s. \_\_\_\_\_ (Name of Bidder) hereby certify that we meet the minimum Local content for the Goods and services offered vide our offer/bid No.

\_\_\_\_\_ dated \_\_\_\_\_ as specified below:

- Class-I Local Supplier with local content of 50% and above
- OR
- Class-II Local Supplier with local content of 20% and above but less than 50%

(Tick appropriate category of Local Supplier)

Minimum Local content is \_\_\_\_\_% as per Price break up given below:

Component of cost Imported product Domestic value addition to product In Foreign Currency US\$ or specify In Rupees

Exchange Rate @ 1 US\$ = Rs In Rupees Location of value addition Goods

Material

ii Equipment

iii Total Quoted Price =

(X + Y)

X =

Y =

% Local Content =  $(\frac{Y}{X+Y}) \times 100$

We are not claiming the services such as transportation, insurance, installation, commissioning, training, after sales service (warranty or AMC/CMC support), consultancy and custom clearance including custom duty as local value addition. These costs should not be included in Y above.

We are aware that the false declarations will be in breach of the Code of Integrity under Rule 175(1)(i)(h) of the General Financial Rules (Govt of India) for which we or our successors can be debarred for up to two years as per Rule 151 (iii) of the General Finance Rules along with such other actions as may be permissible under law.

Signed: [insert signature of person whose name and capacity are shown]

In the capacity of [insert legal capacity of person signing the Bid Submission Form]

Name: [insert complete name of person signing the Bid Submission Form]

Duly authorized to sign the bid for and on behalf of: [insert complete name of Bidder]

Dated on \_\_\_\_\_ day of \_\_\_\_\_, \_\_\_\_\_ [insert date of signing]



## **ANNEXURE-VIII**

### **Self-Certification**

With reference to Clause No. 1.1.3 of this tender and GoI Ministry of Finance Order No.: F. No. 6/18/2019-PPD dated 23rd July, 2020 on "Restrictions under Rule 144 (xi) of the General Financial Rules (GFRs)" & OM No. F. No. 18/37/2020-PPD dated 8thFebruary, 2021;

It is certified that

We are not a bidder of a country which shares a land border with India. OR

We are a bidder of a country which shares a land border with India, however, we are eligible to bid in any procurement whether of goods or services as we are registered with the Competent Authority as specified in Ministry of Finance (GoI) Order No. 6/18/2019 – PPD dated 23rd July 2020. Copy of valid registration is attached.

Tick as applicable

Place:

Date:

Authorised Signatory

Name:

Company Seal

**ANNEXURE IX**

**Self-Certification under preference to Make in India order Certificate**

In line with Government Public Procurement Order No. P-45021/2/2017-PP (BE-II) dated 04.06.2020 issued by Ministry of Commerce and Industry and subsequent amendment of the order dt 16<sup>th</sup> September 2020 we hereby certify that we M/s. .... are local supplier meeting the requirement of minimum local content (i.e. amount of value addition) .....% as defined in above orders for the item/s against Enquiry/Tender No ..... Details of location at which local value addition is made for the item/s are as follows

.....  
.....

We also understand false declarations will be in breach of the code of integrity under rule 175(1)(i)(h) of the General Financial Rules for which a bidder or its successors can be debarred for upto two years as per Rule 151(iii) of the General Financial Rules along with such other actions as may be permissible under law.

Signature of vendor with stamp

## **PRE CONTRACT INTEGRITY PACT**

### **General**

This pre-bid pre-contract Agreement (hereinafter called the Integrity Pact) is made on \_\_\_\_\_, between on one hand, the President of India acting through Dr. G.A.Ramadass, Director, NIOT, Ministry of Earth Science, Government of India (hereinafter called the "BUYER", which expression shall mean and include, unless the context otherwise requires, his successors in office and assigns) of the First part and represented by Shri \_\_\_\_\_, (hereinafter called the BIDDER/Seller" which expression shall mean and include, unless the context otherwise requires, his successors and permitted assigns) of the Second Part. WHEREAS the BUYER proposes a service for "**Deep Ocean Simulator (DOS) – 1500 bar**" and the BIDDER/Seller is willing to offer/has offered the stores and

WHEREAS the Bidder is a private company/public company/Government undertaking/partnership/registered export agency, constituted in accordance with the relevant law in the matter and the BUYER is a Ministry/Department of the Government of India/PSU performing its functions on behalf of the President of India.

NOW THEREFORE,

To avoid all forms of corruption by following a system that is fair, transparent and free from any influence/prejudices dealings prior to, during and subsequent to the currency of the contract to be entered into with a view to:-

Enabling the BUYER to obtain the desired said stores/equipment at a competitive price in conformity with the defined specifications by avoiding the high cost and the distortionary impact of corruption on public procurement, and

Enabling BIDDERS to abstain from bribing or indulging in any corrupt practice in order to secure the contract by providing assurance to them that their competitors will also abstain from bribing and other corrupt practices and the BUYER will commit to prevent corruption, in any form, by its officials by following transparent procedures.

The parties hereto hereby agree to enter into this Integrity Pact and agree as follows:

### **Commitments of the BUYER**

The BUYER undertakes that no official of the BUYER, connected directly or indirectly with the contract, will demand, take a promise for or accept, directly or through intermediaries, any bribe, consideration, gift, reward, favour or any material or immaterial benefit or any other advantages from the BIDDER, either

for themselves or for any person, organization or third party related to the contract in exchange for an advantage in the bidding process, bid evaluation, contracting or implementation process related to the contract.

The BUYER will, during the pre-contract stage, treat all BIDDERS alike, and will provide to all BIDDERS the same information and will not provide any such information to any particular BIDDER which could afford an advantage to that particular BIDDER in comparison to other BIDDERS

All the officials of the BUYER will report to the appropriate Government office any attempted or completed breaches of the above commitments as well as any substantial suspicion of such a breach.

2. In case any such preceding misconduct on the part of such official(s) is reported by the BIDDER to the BUYER will full and verifiable facts and the same is prima facie found to be correct by the BUYER, necessary disciplinary proceedings, or any other action as deemed fit, including criminal proceedings may be initiated by the BUYER and such a person shall be debarred from further dealings related to the contract process. In such a case while an enquiry is being conducted by the BUYER the proceedings under the contract would not be stalled.

### **Commitments of BIDDERS**

3. The BIDDER commits itself to take all measures necessary to prevent corrupt practices, unfair means and illegal activities during any stage of its bid or during any pre-contract or post-contract stage in order to secure the contract or in furtherance to secure it and in particular commit itself to the following:-

The BIDDER will not offer directly or through intermediaries, any bribe, gift, consideration, reward favour, any material or immaterial benefit or other advantage, commission, fees, brokerage or inducement to any official of the BUYER, connected directly or indirectly with the bidding process, or to any person, organization or third party related to the contract in exchange for any advantage in the bidding, evaluation, contracting and implementation of the contract.

The BIDDER further undertakes that it has not given, offered or promised to give, directly or indirectly any bribe, gift, consideration, reward favour, any material or

immaterial benefit or any other advantage, commission, fees, brokerage or inducement to any official of the BUYER, or otherwise in procuring the Contract or forbearing to do or having done any act in relation to the obtaining or execution of the contract or any other contract with the Government for showing or forbearing to show favour or disfavor to any person in relation to the contract or any other contract with the Government.

BIDDERS shall disclose the name and address of agents and representatives and Indian BIDDERS shall disclose their foreign principles or associates.

BIDDERS shall disclose the payments to be made by them to agents/brokers or any other intermediary in connection with this bid/contract.

The BIDDER further confirms and declares to the BUYER that the BIDDER is the original manufacturer / integrator / authorized government sponsored export entity of the defect stores and has not engaged any individual or firm or company whether Indian or foreign to intercede, facilitate or in any way to recommend to the BUYER or any of its functionaries whether officially or unofficially to the award of the contract to the BIDDER, nor has any amount been paid, promised or intended to be paid to any such individual, firm or company in respect of any such intercession, facilitation or recommendation.

The BIDDER, either while presenting the bid or during pre contract negotiations or before signing the contract, shall disclose any payments he has made, is committed to or intends to make to officials of the BUYER or their family members, agents, brokers or any other intermediaries in connection with the contract and the details of services agreed upon for such payments.

The BIDDER will not collude with other parties interested in the contract to impair the transparency, fairness and progress of the bidding process, bid evaluation, contracting and implementation of the contract.

The BIDDER will not accept any advantage in exchange for any corrupt practice, unfair means and illegal activities.

The BIDDER shall not use improperly, for purposes of competition or personal gain, or pass on to others, any information provided by the BUYER as part of the business relationship, regarding plans, technical proposals and business details, including information contained in any electronic data carrier. The BIDDER also undertakes to exercise due and adequate care lest any such information is divulged.

The BIDDER commits to refrain from giving any complaint directly or through any other manner without supporting it with full and verifiable facts.

The BIDDER shall not instigate or cause to instigate any third person to commit any of the actions mentioned above.

If the BIDDER or any employee of the BIDDER or any person acting on behalf of the BIDDER, either directly or indirectly, is a relative of any of the officers of the BUYER, or alternatively, if any relative of an officer of the BUYER has financial interest/stake in the BIDDER's firm, the same shall be disclosed by the BIDDER at the time of filling of tender.

The term 'relative' for this purpose would be as defined in Section 6 of the Companies ACT 1956.

The Bidder shall not lend to or borrow any money from or enter into any monetary dealings or transactions, directly or indirectly, with any employee of the BUYER.

#### **4. Previous Transgression**

The BIDDER declares that no previous transgression occurred in the last three years immediately before signing of this Integrity Pact, with any other company in any country in respect of any corrupt practices envisaged hereunder or with any Public Sector Enterprise in India or any Government

Department in India that could justify BIDDER's exclusion from the tender process.

The BIDDER agrees that if it makes incorrect statement on this subject, BIDDER can be disqualified from the tender process or the contract, if already awarded, can be terminated for such reason.

#### **5. Earnest Money (Security Deposit)**

While submitting commercial bid, the BIDDER shall deposit an amount Rs.58,00,000/- as Earnest Money/Security Deposit, with the buyer as per the following instruments:

- i) A confirmed guarantee by an Indian Nationalized bank, promising payment of the guaranteed sum to the BUYER on demand within three working days without any demur whatsoever and without seeking any reasons whatsoever. The demand for payment by the BUYER shall be treated as conclusive proof of payments.

- ii) Any other mode or through any other instrument (to be specified in the RFP)

The Earnest Money/Security Deposit shall be valid up to a period of five years or the complete conclusion of the contractual obligations to the complete satisfaction of both the BIDDER and the BUYER, including warranty period, whichever is later. In case of the successful BIDDER a clause would also be incorporated in the Article pertaining to Performance Bond in the Purchase Contract that the provisions of Sanctions for Violation shall be applicable for forfeiture of Performance Bond in case of a decision by the BUYER to forfeit the same without assigning any reason for imposing sanction for violation of this pact.

No interest shall be payable by the BUYER to the BIDDER on Earnest Money/Security Deposit for the period of its currency.

## **6. Sanctions for Violations**

Any breach of the aforesaid provisions by the BIDDER or any one employed by it or acting on its behalf (whether with or without the knowledge of the BIDDER) shall entitle the BUYER to take all or any one of the following actions, wherever required:

-

- i) To immediately call off the pre-contract negotiations without assigning any reason or giving any compensation to the BIDDER. However, the proceedings with the other BIDDER(s) would continue.
- ii) The Earnest Money Deposit (in pre-contract stage) and/or Security Deposit/ Performance Bond (after the contract is signed) shall stand forfeited either fully or partially, as decided by the BUYER and the BUYER shall not be required to assign any reason therefore.
- iii) To immediately cancel the contract, if already signed, without giving any compensation to the BIDDER.
- iv) To recover all sums already paid by the BUYER, and in case of an Indian BIDDER with interest thereon at 2% higher than the prevailing Prime Lending Rate of State Bank of India, while in case of a BIDDER from a country other than India with interest thereon at 2% higher than the LIBOR. If any outstanding payment is due to the BIDDER from the BUYER in connection with any other contract for any other stores, such outstanding payment could also be utilized to recover the aforesaid sum and interest.
- v) To encash the advance bank guarantee and performance bond/warranty bond, if furnished by the BIDDER, in order to recover the payments, already made by the BUYER, along with interest.

- vi) To cancel all or any other Contracts with the BIDDER. The BIDDER shall be liable to pay compensation for any loss or damage to the BUYER resulting from such cancellation/ rescission and the BUYER shall be entitled to deduct the amount so payable from the money(s) due to the BIDDER.
- vii) To debar the BIDDER from participating in future bidding processes of the Government of India for a minimum period of Five years, which may be further extended at the discretion of the BUYER.
- viii) To recover all sums paid in violation of this Pact by BIDDER(s) to any middleman or agent or broker with a view to securing the contract.
- ix) In cases where irrevocable Letters of Credit have been received in respect of any contract signed by the BUYER with the BIDDER, the same shall not be opened.
- x) Forfeiture of Performance Bond in case of a decision by the BUYER to forfeit the same without assigning any reason for imposing sanction for violation of this pact.

The BUYER will be entitled to take all or any of the actions mentioned at para 6.1(i) to (x) of this Pact also on the Commission by the BIDDER or any one employed by it or acting on its behalf (whether with or without the knowledge of the BIDDER) of an offence as defined in Chapter IX of the Indian Penal code, 1860 or Prevention of Corruption ACT, 1988 or any other statute enacted for prevention of corruption.

The decision of the BUYER to the effect that a breach of the provisions of this Pact has been committed by the BIDDER shall be final and conclusive on the BIDDER. However, the BIDDER can approach the Independent Monitor(s) appointed for the purposes of this Pact.

## **7. Fall Clause**

The BIDDER undertakes that it has not supplied/is not supplying similar product/systems or subsystems at a price lower than that offered in the present bid in respect of any other Ministry/Department of the Government of India or PSU and if it is found at any stage that similar product/systems or sub systems was supplied by the BIDDER to any other Ministry/Department of the Government of India or PSU at a lower price, then that very price, with due allowance for elapsed time, will be applicable to the present case and the difference in the cost would be refunded by the BIDDER to the BUYER, if the contract has already been concluded.



## **8. Independent Monitors**

The BUYER has appointed Independent Monitors (hereinafter referred to as Monitors) for this Pact in consultation with the Central Vigilance Commission

**Shri. Ajay Kumar Lal, IRAS (Retd)**

e-mail: [ajay\\_k\\_lal@yahoo.com](mailto:ajay_k_lal@yahoo.com)

Mobile: 9560712003

Address: HIG, Block 3A/101A,  
Motia Khan (near Jhandewalan  
Temple), D.B. Gupta Road,  
New Delhi – 110015.

**Shri. Pavan Kumar Jain, IDSE (Retd)**

e-mail: [msgpkj@gmail.com](mailto:msgpkj@gmail.com)

Mobile: 9313498388

Address: A-402, Shree Ganesh Apartments,  
Plot No. 12B, Sector-7, Dwarka,  
New Delhi 110075

The task of the Monitors shall be to review independently and objectively, whether and to what extent the parties comply with the obligations under this pact.

The Monitors shall not be subject to instructions by the representatives of the parties and perform their functions neutrally and independently.

But the parties accept that the Monitors have the right to access all the documents relating to the project/procurement, including minutes of meetings.

As soon as the Monitor notices, or has reason to believe, a violation of this pact, he will so inform the Authority designated by BUYER.

The BIDDER(s) accepts that the Monitor has the right to access without restriction to all Project documentation of the BUYER including that provided by the BIDDER. The BIDDER will also grant the Monitor, upon his request and demonstration of a valid interest, unrestricted and unconditional access to his project documentation. The same is applicable to Subcontractors. The Monitor shall be under contractual obligation to treat the information and documents of the BIDDER/Subcontractor(s) with confidentiality.

The BUYER will provide to the Monitor sufficient information about all meetings among the parties related to the Project provided such meetings could have an impact on the contractual relations between the parties. The parties will offer to the Monitor the option to participate in such meetings.

The Monitor will submit a written report to the designated Authority of BUYER/Secretary in the Department/within 8 to 10 weeks from the date of reference or intimation to him by the BUYER/BIDDER and, should the occasion arise, submit proposals for correcting problematic situations.

#### **9. Facilitation of Investigation**

In case of any allegation of violation of any provisions of this Pact or payment of commission, the BUYER or its agencies shall be entitled to examine all the documents including the Books of Accounts of the BIDDER and the BIDDER shall provide necessary information and documents in English and shall extend all possible help for the purpose of such examination.

#### **10. Law and Place of Jurisdiction**

This Pact is subject to Indian Law. The place of performance and jurisdiction is the seat of the BUYER.

#### **11. Other Legal Actions**

The actions stipulated in this Integrity Pact are without prejudice to any other legal action that may follow in accordance with the provisions of the extant law in force relating to any civil or criminal proceedings.

#### **12. Validity**

The validity of this Integrity pact shall be from date of its signing and extend upto 5 years or the complete execution of the contract to the satisfaction of both the BUYER and the BIDDER/Seller, including warranty period, whichever is later. In case BIDDER is unsuccessful, this Integrity Pact shall expire after six months from the date of the signing of the contract.

Should one or several provisions of this pact turn out to be invalid; the remainder of this act shall remain valid. In this case, the parties will strive to come to an agreement to their original intentions.

**13.** The parties hereby sign this Integrity Pact at \_\_\_\_\_ NIOT Chennai on

**THE DIRECTOR**

National Institute of Ocean Technology  
Ministry of Earth Sciences

**BIDDER**

M/s.

Witness

1. \_\_\_\_\_

2. \_\_\_\_\_

1. \_\_\_\_\_

2. \_\_\_\_\_

**Consortium agreement**

This Consortium Agreement (“Agreement”) entered into at Chennai, India on this day of  
2023

BY AND BETWEEN

M/s. \_\_\_\_\_, an entity constituted in accordance with the laws of [Name of the Country] and having its Office at \_\_\_\_\_, acting through its duly authorized representative, Mr. / Ms. \_\_\_\_\_ [Please insert name and designation] (hereinafter referred to as the ‘First Participant Member’ which expression unless excluded by or repugnant to the subject or context be deemed to mean and include its successors-in-interest, authorized representatives, administrators, and permitted assigns) of the First Part;

AND

M/s. \_\_\_\_\_, an entity constituted in accordance with the laws of [Name of the Country] and having its Office at \_\_\_\_\_, acting through its duly authorized representative, Mr. / Ms. \_\_\_\_\_ [Please insert name and designation] (hereinafter referred to as the ‘Second Participant Member’ which expression unless excluded by or repugnant to the subject or context be deemed to mean and include its successors-in-interest, authorized representatives, administrators, and permitted assigns) of the Other Part.

WHEREAS National Institute of Ocean Technology, being a Society incorporated under the laws of Government of India and having its Registered Office at NIOT Campus, Velachery - Tambaram Main Road, Pallikaranai, Chennai – 600 100, Tamilnadu, India (hereinafter called “NIOT”) had invited bids for Deep Ocean Simulator (DOS) – 1500 bar as per tender specification and terms and conditions for NIOT, Chennai. (hereinafter called the “Project”) and the bid conditions require that the applicants bidding for the same should form a Consortium for bidding as well as executing the Project.

AND WHEREAS the Parties of the First and Second Parts jointly satisfy the eligibility criteria laid down by NIOT for participating in the bidding process by forming a Consortium between themselves.

The Parties hereby form such a Consortium subject to the following terms and conditions and this Agreement shall form a part and parcel of the Agreement for a Deep Ocean Simulator (DOS) as per tender specification and terms and conditions for NIOT, Chennai. if and when awarded to the Parties hereto:

**1. Object:**

The object of this agreement is for the parties herein to arrive at a strategic understanding with each other to pool their resources, cooperate with each other and jointly prepare and submit their bid and in case the Agreement for a Deep Ocean Simulator (DOS) – 1500 awarded for execution of the Project by NIOT, to take up the same and implement it as per its terms.

**2. Exclusivity:**

The Parties herein agree that no party shall withdraw from this Agreement at the time of bidding as well as during the execution of the Project and the Agreement for a Deep Ocean Simulator (DOS) – 1500 (if awarded) for any reason, whatsoever, without the prior written approval and consent of NIOT.

The Parties herein also have represented and assured each other that they will abide by and be bound by the terms and conditions stipulated by NIOT for awarding the Deep Ocean Simulator (DOS) – 1500 including signing contract with all stake holders/foreign principal in the execution of this Agreement and the above-mentioned Agreement for Deep Ocean Simulator (DOS) – 1500.

**3. Project Coordinator:**

After the bidding process, if the contract is awarded to the Parties herein as a Consortium, the Parties hereby agree that the Party of the First Part shall act as the Lead Partner for self and on behalf of the other parties and shall enter into and execute the Agreement for Deep Ocean Simulator (DOS) – 1500 for itself and on behalf of the other parties. The parties herein further declare and confirm that they are jointly and severally bound to NIOT for execution of the Agreement for Deep Ocean Simulator (DOS) – 1500 in accordance with its terms and shall jointly and severally be liable to NIOT to perform all contractual obligations, including technical guarantees mentioned therein and in this Agreement. The Lead Partner is authorized to incur liabilities and receive instructions for and on behalf of any or all Partners of the Consortium.

**4. Responsibility and Obligations of the Parties:**

The responsibilities and obligations of each of the Parties herein shall be as delineated in Annexure - I to this Agreement. In line with the past experience and specialization of the Parties herein each Party will be responsible for the work allocated to them as per Annexure - I aforesaid. It is agreed that the financial responsibility of the works identified in Annexure - I shall be as described against each item by respective consortium partner. It is further agreed that the above-mentioned sharing of responsibilities and obligations shall not in any way be a limitation to the joint and several responsibilities of the Parties herein to NIOT under the project or the Agreement Deep Ocean Simulator (DOS) – 1500 (if awarded by NIOT).

**5. Cooperation:**

The Lead Partner undertakes to cooperate with the other Parties in order to ensure smooth performance and execution of the Project and the Agreement for Deep Ocean Simulator (DOS) – 1500 (if awarded by NIOT). The Lead Partner undertakes to provide NIOT with all information at its disposal for due performance of the Agreement for Deep Ocean Simulator (DOS) – 1500, (in case the same is awarded by NIOT). The Parties herein also undertake to inform in time each other and NIOT

regarding any financial problems or other impediments which may have an impact on the timely execution of the Project or performance of the Agreement for System configuration, supply, installation, commissioning, and operational training of a Deep Ocean Simulator (DOS) ,(if awarded by NIOT) and shall take all remedial measures to ensure successful performance of all the obligations of the consortium hereunder and under the Agreement for Deep Ocean Simulator (DOS) – 1500), (if awarded by NIOT).

Notwithstanding the Lead Partner's liability in terms of this Agreement, each Party shall be fully responsible, liable and accountable for all financial transactions under this Agreement and the Agreement for Deep Ocean Simulator (DOS) – 1500 and each Party shall pay its own taxes and make other statutory and mandatory payments / taxes / duties. The Parties herein further undertake to ensure that all applicable legal regulations are observed, appropriate records are kept of all financial transactions and appropriate documentation, including, but not limited to contracts, orders and confirmations, receipts and invoices, time sheets of staff and payroll calculations are retained for all matters pertaining to this Agreement and the Agreement for Deep Ocean Simulator (DOS) – 1500), (if awarded by NIOT).

The Lead Partner shall be responsible to maintain contact with NIOT and request clarification, guidance or advice whenever needed. The other Parties herein shall route all their requests with regard to clarification and guidance through the Lead Partner.

**6. Conflict of Interest:**

The Parties herein undertake to take all necessary measures in order to avoid any conflict of interest during the performance of the Agreement or the project or the Agreement for Deep Ocean Simulator (DOS) – 1500), (if awarded by NIOT) and also to identify any conflict of interest so that NIOT can consult with the Lead Partner and other Parties to sort out such conflicts.

**7. Post Contract Liabilities:**

For any loss or damage on account of any breach of this Agreement or the Agreement for Deep Ocean Simulator (DOS) – 1500), (if awarded by NIOT) or any shortfall in the execution of the Project (if awarded by NIOT) meeting the guaranteed performance / parameters as per technical specifications / documents relating to the Tender or the Agreement for Deep Ocean Simulator (DOS) – 1500), (if awarded by NIOT), the Lead Partner as well as the other Parties undertake to promptly make good such loss or damage on NIOT's demand without any demur. NIOT shall have the right to proceed against any one of the Parties herein in this regard and it shall neither be necessary nor obligatory on the part of NIOT to proceed against the Lead Partner before proceeding against the other Parties herein.

**8. Assignment:**

The rights and obligations of First and Second Participant Member under this Agreement shall not be

assigned to any third party without the prior written consent of NIOT.

**9. Employers' responsibility:**

Each Party will be responsible according to the applicable laws and rules for their own personnel and property.

**Roles and Responsibilities:**

The role and responsibilities of each of the consortium partners to be indicated as Appendix I.

**10. Insurance:**

The Parties herein shall at their own expense take out and maintain insurance cover as may be necessary to cover their liabilities.

The contractor shall obtain and maintain insurance policies for self and his subcontractors of adequate value for its personnel, property, to cover workmen's compensation insurance as per law, employers liability insurance for bodily injuries & occupational diseases, comprehensive general liability insurance for bodily injuries and property damages to cover legal liabilities in India to third parties in respect of third party property damage or loss or personal injury or death of any third party in connection with the work and copies of such policies shall be provided to NIOT for review.

**11. Applicable Law:**

This Consortium Agreement shall be governed, construed and interpreted in accordance with the laws of India and the Courts in Chennai shall have the exclusive jurisdiction in all matters arising hereunder.

**12. Further documents:**

To meet the requirements of bid documents or any other stipulations of NIOT, if it becomes necessary to execute and record any other documents amongst the Parties to this Agreement, the Parties herein undertake to do the needful and to participate in the same for the performance of the said Project (if awarded).

**13. Part of Contract:**

It is further agreed by the Parties herein that this Consortium Agreement shall be irrevocable and shall form an integral part of the Agreement for Deep Ocean Simulator (DOS) – 1500, (if awarded) and shall continue to be enforceable against the Parties herein by NIOT till the terms of the Agreement for Deep Ocean Simulator (DOS) – 1500 (if awarded) are fulfilled. It shall be effective on the date first mentioned above for all purposes and intends.

IN WITNESS WHEREOF, the Parties herein have through their respective authorized representatives have executed these presents and affixed their hands and common seal of the respective companies on the day, month and year aforementioned.

For M/s. \_\_\_\_\_ (To be signed by all Consortium partners duly indicating their designation and official seal)

WITNESS

Name:

Designation: